



# Instruction Manual Book

Item code: BH184

# HE-111

Glow and EP

95% PRE BUILT  
**ARF**  
ALMOST READY TO FLY



ALL Balsa - PLY WOOD CONSTRUCTION.  
COVERED IN A HEAT-SHRINK FILM WITH PRINTED.

## 95% ALMOST READY TO FLY

### **SPECIFICATION:**

- Wingspan: 2,500 mm (98.42 in).
- Length: 1,845 mm (72.63 in).
- Weight: 12.5-13 kg (27.5 – 28.6 lbs).
- Wing area: 106.8dm<sup>2</sup>.
- Wing loading: 117.04g/dm<sup>2</sup>.
- Servo mount: size (42 x 21)mm.
- Wing type: Naca airfoils.
- Main gear type: Electric retract gear with oleo struts for main gear(included).
- Tail gear type: Oleo struts for tail gear (included).

### **Parts listing required (not included):**

- Radio: 08 channels minimum.
- Servo: 9 - 11 standard high torque servos.
- Engine: 20CC GAS (2 pcs).
- Motor: Brushless outrunner 1800-2300W, 450KV.
- Propeller: Suit with your engine.

### **Recommended Motor**

### **and Battery set up (not included):**

- Motor: Admiral GP20 6320-295KV Brushless (2pcs).
- Lipo cell: 6-10 cells 4,000-5,000mAh ( 2 Packs).
- ESC: 80A (2pcs).
- Receiver battery: 6V/7.4V 1200-2000mAh.

# TABLE OF CONTENTS

▶ Introduction.....	2	▶ Installing the gear door. ....	22
▶ Warranty.....	3	▶ Installing the fuselage servos.....	26
▶ Disclaimer.....	3	▶ Installing horizontal stabilizer.....	27
▶ Safety precaution.....	3	▶ Installing vertical stabilizer.....	31
▶ Important building notes.....	3	▶ Installing the tail gear.....	33
▶ Suggestion.....	3	▶ Secure the wing to the fuselage.....	35
▶ Flight warnings.....	3	▶ Installing the switch and receiver, battery..	38
▶ Covering tools.....	4	▶ Installing canopy fuselage.....	39
▶ Adhesives and required tools.....	4	▶ Installing plastic fuselage.....	41
▶ Academy of Model Aeronautics National Model Aircraft Safety Code.....	4	▶ Installing the engine mount.....	41
▶ Parts listing (not included).....	6	▶ Installing the engine .....	42
▶ Tools & supplies needed.....	6	▶ Installation the fuel tank.....	43
▶ Symbols used throughout this instruction manual comprise.....	6	▶ Installing the throttle.....	46
▶ Installing the ailerons and flaps.....	9	▶ Mounting the cowl.....	47
▶ Installing the ailerons and flaps servos.....	10	▶ Balancing.....	48
▶ Installing the engine mount.....	15	▶ Lateral balance.....	48
▶ Installing the main gear .....	16	▶ Pre-flight check.....	49
▶ Installing the engine mount.....	17	▶ Control throws.....	49
▶ Installing the electric motor (ep version)..	18	▶ Main gear dimensional detail.....	51
▶ Mounting the cowl.....	19	▶ Tail gear dimensional detail.....	51
▶ Installing the spinner.....	21	▶ Decoration.....	52
		▶ Exploded view.....	53

## INTRODUCTION

Thank you for purchasing Black Horse Model products. With over 18 years experience in production and fly testing, Black Horse Model is committed to bring the best quality products and good service to customers. Along with a team of creative engineers and skilled workers, we will always accompany with customers by our great experiences, fully enthusiasm... which will burn our passion!! Joining with us to explore and conquer challenges in the sky ...

Your satisfaction is our success. Please read through this manual before starting construction.

**Academy of Model Aeronautics:** If you are not already a member of the AMA, please join! The AMA is the governing body of model aviation and membership provides liability insurance coverage, protects modelers' rights and interests and is required to fly at most R/C sites.

**Academy of ModelAeronautics**  
5151 East Memorial Drive Muncie IN 47302-9252

Tele. (800) 435-9262  
Fax. (765) 741-0057

Or via the Internet at: <http://www.modelaircraft.org>



## WARRANTY

Black Horse Model guarantees the component parts in this kit to be free from defects in both material and workmanship at the date of purchase by the purchaser.

This warranty does not cover cosmetic damage or damage due to acts of God, accident, misuse, abuse, negligence, commercial use, or modification of or to any part of the Product.

This warranty does not cover damage due to improper installation, operation, maintenance, or attempted repair by anyone other than Black Horse Model.

Further, Black Horse Model reserves the right to change or modify this warranty without notice.

## DISCLAIMER

Read this disclaimer carefully before using this product. Please strictly follow the instruction manual to assemble and use this.

In that Black Horse Model has no control over the final assembly or material used for final assembly, Black Horse Model is not responsible for loss of use, or other incidental or consequential damages.

Furthermore, Black Horse Model cannot be held liable for personal injury or property damage caused by the use or misuse of Black Horse Model products. By the act of using the user-assembled products, the user accepts all resulting liability.

## SAFETY PRECAUTION

This is not a toy and pilots must be over the age of 14

Be sure that no other flyers are using your radio frequency.

Do not smoke near fuel

Store fuel in a cool, dry place, away from children and pets.

Wear safety glasses.

The glow plug clip must be securely attached to the glow plug.

Do not flip the propeller with your fingers.

Keep loose clothing and wires away from the propeller.

Do not start the engine if people are near. Do not stand in line with the side of the propeller.

Make engine adjustments from behind the propeller only. Do not reach around the spinning propeller.

Moisture causes damage to electronics. Avoid water exposure to all equipment not specifically designed and protected for this purpose.

## IMPORTANT BUILDING NOTES

Please trial fit all the parts. Make sure you have the correct parts and that they fit and are aligned properly before gluing! This will assure proper assembly. This kit is hand made from natural materials, every plane is unique and minor adjustments may have to be made. However, you should find the fit superior and assembly simple.

The painted and plastic parts used in this kit are fuel proof. However, they are not tolerant of many harsh chemicals including the following: paint thinner, C/A glue accelerator, C/A glue debonder and acetone. Do not let these chemicals come in contact with the colors on the covering and the plastic parts.

Some parts included in this kit such as the cowl or wheel pants are made of fiberglass, the fibers of which may cause eye, skin and respiratory tract irritation. Never blow into a part to remove fiberglass dust, as the dust will blow back into your eyes. Always wear safety goggles, a particle mask and rubber gloves when grinding, drilling and sanding fiberglass parts. Vacuum the parts and the work area thoroughly after working with fiberglass parts.

## SUGGESTION

To avoid scratching your new airplane, do not unwrap the pieces until they are needed for assembly. Cover your workbench with an old towel or brown paper, both to protect the aircraft and to protect the table. Keep a couple of jars or bowls handy to hold the small parts after you open the bag.

## FLIGHT WARNINGS

Always operate in open areas, away from factories, hospitals, schools, buildings and houses etc.

NEVER fly your aircraft close to people or built up areas.

NEVER fly near power lines, aerials or other dangerous areas including airports, motorways etc. NEVER fly in wet conditions or on windy or stormy days.

ALWAYS adjust the engine from behind the propeller, and do not allow any part of your body to be in line with the propeller.

**THE PROPELLER IS DANGEROUS** Keep fingers, clothing (ties, shirt sleeves, scarves) or any other loose objects that could be caught or drawn in, away from the propeller. Take care at ALL times. NEVER use damaged or deformed propellers or spinners.

Keep all onlookers (especially small children and animals) well back from the area of operation. This is a flying aircraft, which will cause serious injury in case of impact with a person or animal.

DO NOT dispose of empty fuel containers on a fire, this can lead to an explosion.

## FLIGHT WARNINGS

When ready to fly, first extend the transmitter aerial.

Switch on the transmitter.

Switch on the receiver.

Check that the wings are correctly fitted to the fuselage.

Operate the control sticks on the transmitter and check that the control surfaces move freely and in the CORRECT directions.

Check that the transmitter batteries have adequate power.

ALWAYS take off into the wind.

If the model does not respond correctly to the controls, land it as soon as possible and correct the fault.

ALWAYS land the model INTO the wind, this ensures that the model lands at the slowest possible speed.

Switch off the receiver.

Switch off the transmitter.

Empty the fuel tank after flying, fuel left in the tank can cause corrosion and lead to engine problems.

## COVERING TOOLS

Top Flite® MonoKote® Sealing Iron

Top Flite Hot Sock Iron Cover

Top Flite MonoKote Trim Seal Iron

Top Flite MonoKote Heat Gun

## ADHESIVES AND REQUIRED TOOLS

Thin CA

30-minute epoxy

6-minute epoxy

Threadlocker thread locking cement

Mixing sticks

Mixing cups (GPMR8056)

Epoxy brushes

Denatured alcohol

Canopy Glue

Felt-tipped pen or pencil

Flat screwdriver

Adjustable wrench

Drill

Hobby knife

Masking tape

Phillips screwdriver (large)

Phillips screwdriver (small)

Ruler

Sandpaper

Soldering iron

Solder

Hex wrench

Drill bit: 1/16-inch (1.5mm), 5/64-inch (2mm),

1/8-inch (3,2mm), 3/16-inch (4,8mm), 11/64-inch (4.5mm), 13/64-inch (5,2mm), 1/4-inch (6,4mm)

## Academy of Model Aeronautics National Model Aircraft Safety Code

### *Effective January 1, 2018*

A. GENERAL: A model aircraft is a non-human-carrying device capable of sustained flight within visual line of sight of the pilot or spotter(s). It may not exceed limitations of this code and is intended exclusively for sport, recreation, education and/or competition. All model flights must be conducted in accordance with this safety code and related AMA guidelines, any additional rules specific to the flying site, as well as all applicable laws and regulations.

As an AMA member I agree:

- I will not fly a model aircraft in a careless or reckless manner.
- I will not interfere with and will yield the right of way to all human-carrying aircraft using AMA's See and Avoid Guidance and a spotter when appropriate.
- I will not operate any model aircraft while I am under the influence of alcohol or any drug that could adversely affect my ability to safely control the model.
- I will avoid flying directly over unprotected people, moving vehicles, and occupied structures.
- I will fly Free Flight (FF) and Control Line (CL) models in compliance with AMA's safety programming.
- I will maintain visual contact of an RC model aircraft without enhancement other than corrective lenses prescribed to me. When using an advanced flight system, such as an autopilot, or flying First-Person View (FPV), I will comply with AMA's Advanced Flight System programming.
- I will only fly models weighing more than 55 pounds, including fuel, if certified through AMA's Large Model Airplane Program.
- I will only fly a turbine-powered model aircraft in compliance with AMA's Gas Turbine Program.
- I will not fly a powered model outdoors closer than 25 feet to any individual, except for myself or my helper(s) located at the flightline, unless I am taking off and landing, or as otherwise provided in AMA's Competition Regulation.
- I will use an established safety line to separate all model aircraft operations from spectators and bystanders.

- Officially designated AMA Air Show Teams (AST) are authorized to use devices and practices as defined within the Team AMA Program Document. (AMA Document #718.)
- (j) Not operate a turbine-powered aircraft, unless in compliance with the AMA turbine regulations. (AMA Document #510-A.)
- 3. Model aircraft will not be flown in AMA sanctioned events, air shows or model demonstrations unless:
  - (a) The aircraft, control system and pilot skills have successfully demonstrated all maneuvers intended or anticipated prior to the specific event.
  - (b) An inexperienced pilot is assisted by an experienced pilot.
- 4. When and where required by rule, helmets must be properly worn and fastened. They must be OSHA, DOT, ANSI, SNELL or NOCSAE approved or comply with comparable standards.
- B. RADIO CONTROL (RC)
  - 1. All pilots shall avoid flying directly over unprotected people, vessels, vehicles or structures and shall avoid endangerment of life and property of others.
  - 2. A successful radio equipment ground-range check in accordance with manufacturer's recommendations will be completed before the first flight of a new or repaired model aircraft.
  - 3. At all flying sites a safety line(s) must be established in front of which all flying takes place. (AMA Document #706.)
    - (a) Only personnel associated with flying the model aircraft are allowed at or in front of the safety line.
    - (b) At air shows or demonstrations, a straight safety line must be established.
    - (c) An area away from the safety line must be maintained for spectators.
    - (d) Intentional flying behind the safety line is prohibited.
  - 4. RC model aircraft must use the radio-control frequencies currently allowed by the Federal Communications Commission (FCC). Only individuals properly licensed by the FCC are authorized to operate equipment on Amateur Band frequencies.
  - 5. RC model aircraft will not knowingly operate within three (3) miles of any pre-existing flying site without a frequency-management agreement. (AMA Documents #922 and #923.)
  - 6. With the exception of events flown under official AMA Competition Regulations, excluding takeoff and landing, no powered model may be flown outdoors closer than 25 feet to any individual, except for the pilot and the pilot's helper(s) located at the flightline.
  - 7. Under no circumstances may a pilot or other person touch an outdoor model aircraft in flight while it is still under power, except to divert it from striking an individual.
  - 8. RC night flying requires a lighting system providing the pilot with a clear view of the model's attitude and orientation at all times. Hand-held illumination systems are inadequate for night flying operations.
  - 9. The pilot of an RC model aircraft shall:
    - (a) Maintain control during the entire flight, maintaining visual contact without enhancement other than by corrective lenses prescribed for the pilot.
    - (b) Fly using the assistance of a camera or First-Person View (FPV) only in accordance with the procedures outlined in AMA Document #550.
    - (c) Fly using the assistance of autopilot or stabilization system only in accordance with the procedures outlined in AMA Document #560.
- C. FREE FLIGHT
  - 1. Must be at least 100 feet downwind of spectators and automobile parking when the model aircraft is launched.
  - 2. Launch area must be clear of all individuals except mechanics, officials, and other fliers.
  - 3. An effective device will be used to extinguish any fuse on the model aircraft after the fuse has completed its function.
- D. CONTROL LINE
  - 1. The complete control system (including the safety thong where applicable) must have an inspection and pull test prior to flying.
  - 2. The pull test will be in accordance with the current Competition Regulations for the applicable model aircraft category.
  - 3. Model aircraft not fitting a specific category shall use those pull-test requirements as indicated for Control Line Precision Aerobatics.
  - 4. The flying area must be clear of all utility wires or poles and a model aircraft will not be flown closer than 50 feet to any above-ground electric utility lines.
  - 5. The flying area must be clear of all nonessential participants and spectators before the engine is started.

**PARTS LISTING (NOT INCLUDED)**

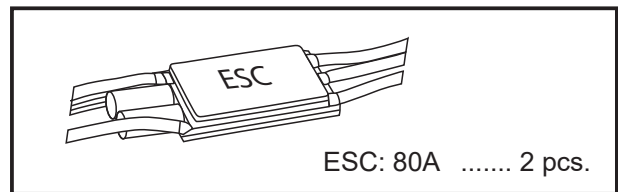
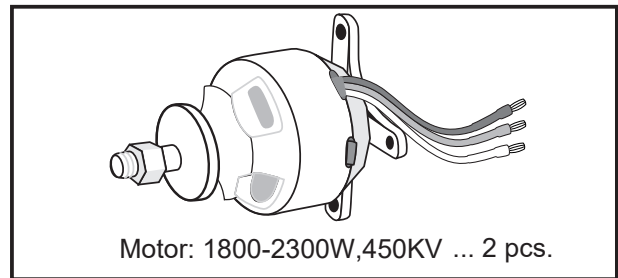
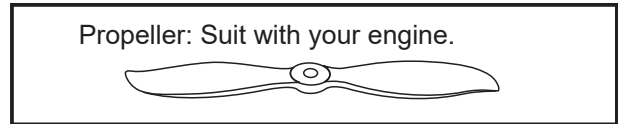
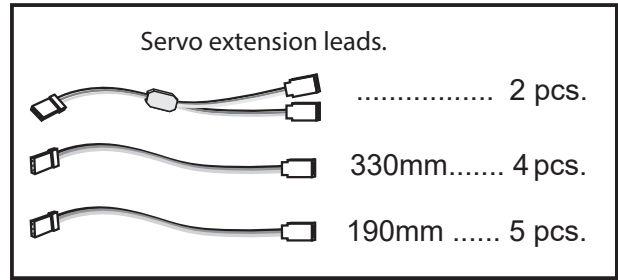
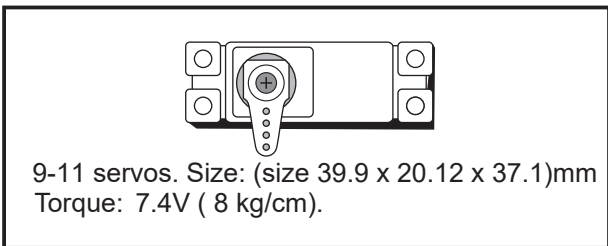
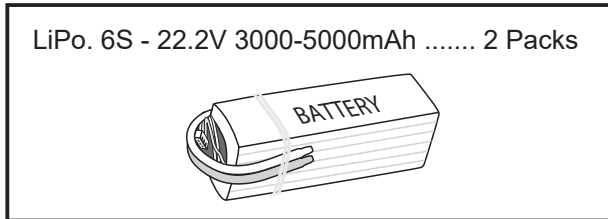
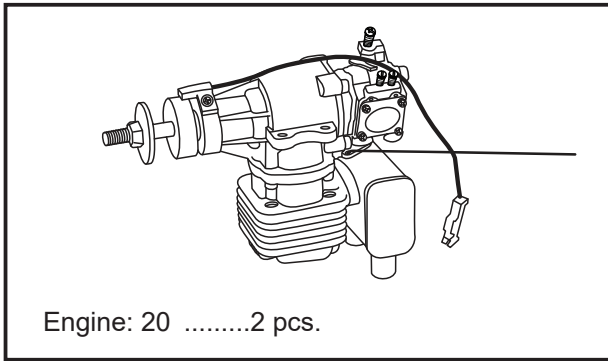

**TOOLS & SUPPLIES NEEDED**

Medium C/A glue  
Threadlocker (screw cement).  
Modeling knife.

Straight edge ruler.  
2 bender plier  
Wire cutters.  
Pencil

EPOXY A  
EPOXY B  
30 minute epoxy.  
5 minute epoxy.  
Screw driver

Hex Wrench.  
Hand or electric drill.

Some more tools.

- Assorted drill bits.
- Masking tape.
- Paper towels.
- Rubbing alcohol
- 90° square or builder's triangle.

**Symbols used throughout this instruction manual, comprise:**

Cut off excess.	Apply threadlocker (screw cement).	Must be purchased separately!
Cut off shaded portion carefully.	Apply instant glue (C.A glue, super glue).	Ensure smooth, non-binding movement when assembling.
Pay close attention here.	Apply epoxy glue.	Drill holes using the stated. (in this case 1.5mm Ø).
Take particular care here.	Assemble left and right sides the same way.	The number of times the same way Assembly (in this case twice).
<b>Warning!</b>	Set all screws securely. If they come off during flight you will lose control of your aircraft!	

- ① : Fuselage (1a,1b: Engin mount; 1c,1d: Motor mount).
- ② : Wing (2a: Left wing, 2b: Right wing).
- ③ : Canopy fuselage ( 3a: front canopy, 3b: main canopy, 3c: top canopy, 3d: Bottom canopy, 3e: Pilot).
- ④ : Horizontal stabilizer.
- ⑤ : Rudder.
- ⑥ : Cowling ( 3a: Left cowling, 3b: Right cowling).
- ⑦ : Spinner.
- ⑧ : Aluminium wing dihedral brace (8a, 8b).
- ⑨ : Tail gear spare part.
- ⑩ : Fuel tank spare part (11a: Clunk, 11b: Sttoper (three line)).
- ⑪ : Electric motor spare part.
- ⑫ : Engine spare part.
- ⑬ : Main gear spare part (7a: Controller Box)
- ⑭ : Gear door spare part.

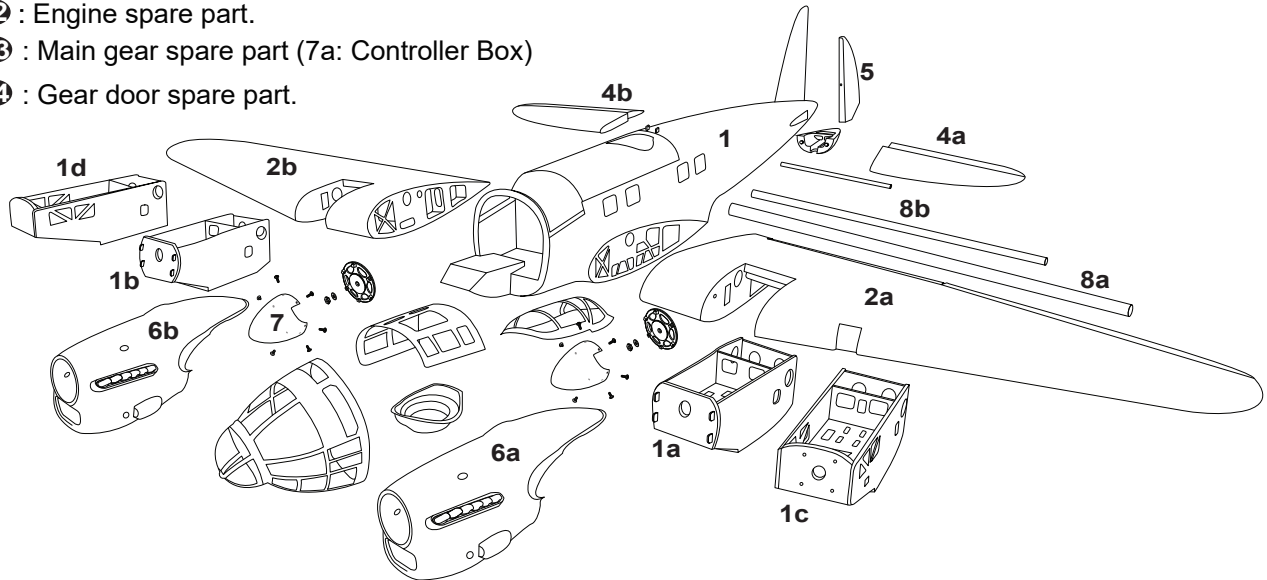
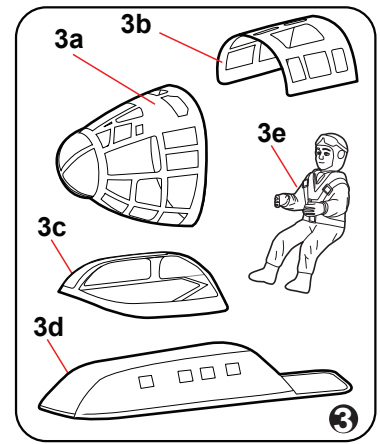

<p>44mm Pinned hinge --- 8</p> <p>67mm Pinned hinge --- 6</p> <p>Horn --- 2</p>	<p>Horn --- 2</p> <p>Horn --- 2</p>	<p>2.6x70mm Push rod --- 2</p> <p>2.6x80mm Push rod --- 2</p> <p>Ball link --- 8</p>	<p>3x12mm Button Head Cap Screw --- 8</p> <p>3mm Lock Nut --- 8</p>	<p>3mm Flat Washer --- 4</p> <p>2x10mm Tp Screw --- 16</p>
<p>995mm Ø32 Aluminium --- 1</p>		<p>772mm Ø19 Aluminium --- 1</p>		

②







<p>4x20mm Button Head Cap Screw --- 8</p> <p>5x7mm Collar --- 4</p> <p>Controller Box --- 1</p>	<p>4mm Flat washer --- 8</p> <p>115mm Wheel --- 2</p>	<p>4mm Spring Washer --- 8</p> <p>5x78mm Metal --- 2</p>

⑬

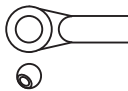



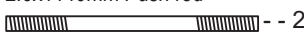

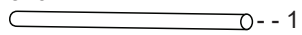
<p>4x15mm Socket Head Cap Screw --- 8</p> <p>4mm Flat Washer --- 8</p>	<p>M4 Blind Nut --- 8</p> <p>4mm Spring Washer --- 8</p>

⑪

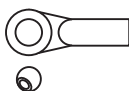



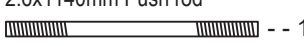



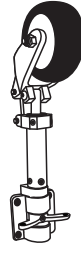

**4**

Horn  --- 2	Ball link  --- 4	44mm Pinned Hinge  --- 10	3mm Lock Nut  --- 4
 --- 2	2.6x1140mm Push rod  --- 2	3x12mm Button Head Cap Screw  --- 4	3mm Flat Washer  --- 4
			340mm Ø 12 Aluminium  --- 1















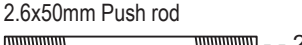

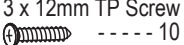
**5**

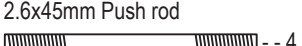
Horn  --- 1	Ball link  --- 2	44mm Pinned Hinge  --- 3	3mm Lock Nut  --- 2	
 --- 1	2.6x1140mm Push rod  --- 1	3x12mm Button Head Cap Screw  --- 2	3mm Flat Washer  --- 2	

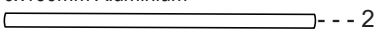











**7**

1200mm Cable rod  --- 2	Locknut  --- 4	3mm Hex Nut  --- 2		 --- 2
3x30mm Cablink  --- 2	3x15mm Socket Head Cap Screw  --- 4	3mm Spring Washer  --- 4		
M3 Metal Clevis  --- 2	3mm Flat Washer  --- 4	3x8mm Button Head Cap Screw  --- 6		

**9**

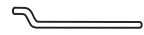

67mm Pinned hinge  --- 8	3x12mm Button Head Cap Screw  --- 12	3mm Flat Washer  --- 16	 --- 6	
2.6x50mm Push rod  --- 2	3x10mm Button Head Cap Screw  --- 16	3 x 12mm TP Screw  --- 10		Collar  --- 4
2.6x45mm Push rod  --- 4	3mm Lock Nut  --- 22	 --- 8		6x136mm Aluminium  --- 2
Ball link  --- 12	L.R  --- 2	4x4mm Set Screw  --- 6	 --- 4	
Gear Door (L,R)		3x4mm Set Screw  --- 4		





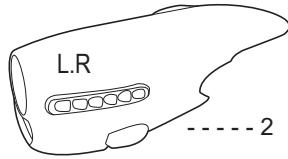

**12**

4x30mm Socket Head Cap Screw  --- 16	M4 Blind Nut  --- 8
4mm Lock Nut  --- 8	5x15mm Socket Head Cap Screw  --- 8
4mm Flat Washer  --- 16	5x16mm Flat Washer  --- 8
4mm Spring Washer  --- 16	Connector  --- 2
500mm Pushrod wire  --- 2	 --- 2
 --- 2	 --- 2

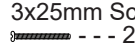
**12**

**6**

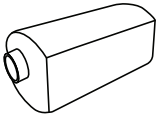
 --- 2	3x12mm TP Screw  --- 10
	Plastic Part (L,R)  --- 4

Clunks  --- 2	3x25mm Screw  --- 2
Rubber  --- 2	Aluminium  --- 2
58mm Copper tube  --- 8	Fiber glass  --- 2
Metal  --- 2	

**10**



# INSTALLING THE AILERONS AND FLAPS

44mm Pinned hinge --- 8  
67mm Pinned hinge --- 6

Horn --- 2

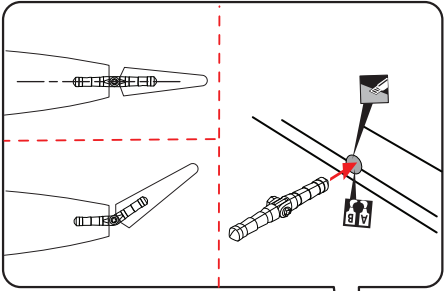
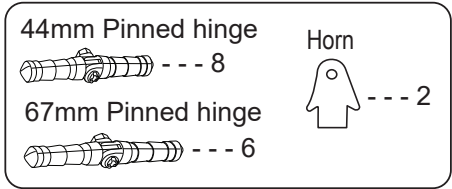

Bottom view

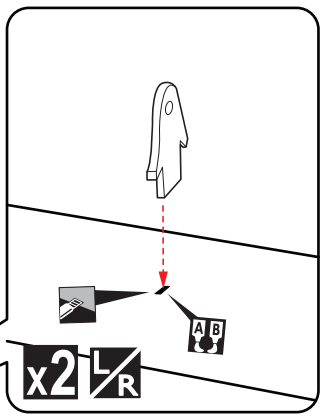
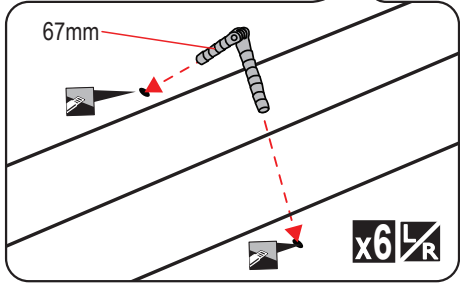
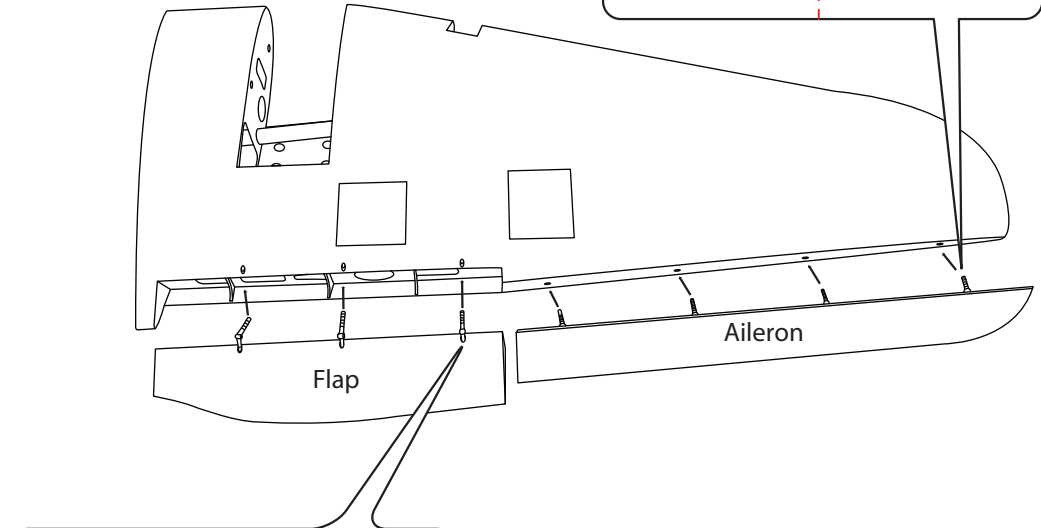

Bottom view

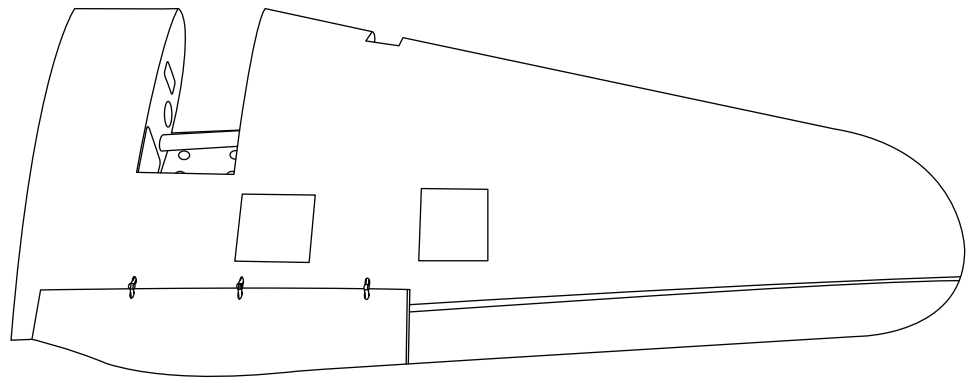
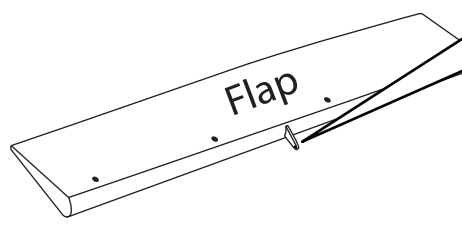

 Cut off shaded portion carefully.

 Apply epoxy glue.

 Ensure smooth, non-binding movement when assembling.

**INSTALLING THE AILERONS AND FLAPS SERVOS**

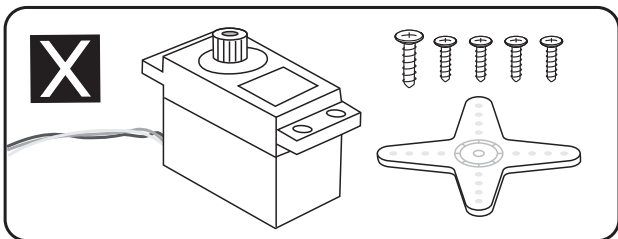

block of wood for each of the four mounting screws provided with the servo.

- 1) Install the rubber grommets and brass eyelets onto the aileron servo.
- 2) Using a modeling knife, remove the covering from over the servo box.
- 3) Place the servo into the servo tray. Center the servo within the tray and drill 1.5mm pilot holes through the

4) Using the thread as a guide and using masking tape, tape the servo lead to the end of the thread: carefully pull the thread out. When you have pulled the servo lead out, remove the masking tape and the servo lead from the thread.

5) Place the servo into the servo tray/ hatch into the servo box on the bottom of the wing and drill 1.5mm pilot holes through the tray and servo box for each of the four mounting screws. Secure the servo tray in place using the mounting screws provided.

6) Repeat step # 2 - # 5 to install the second aileron servo in the opposite wing half.

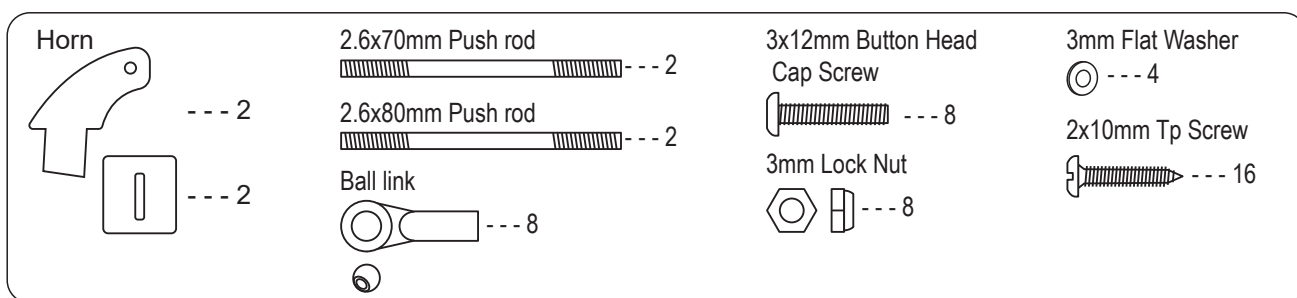

Bottom view

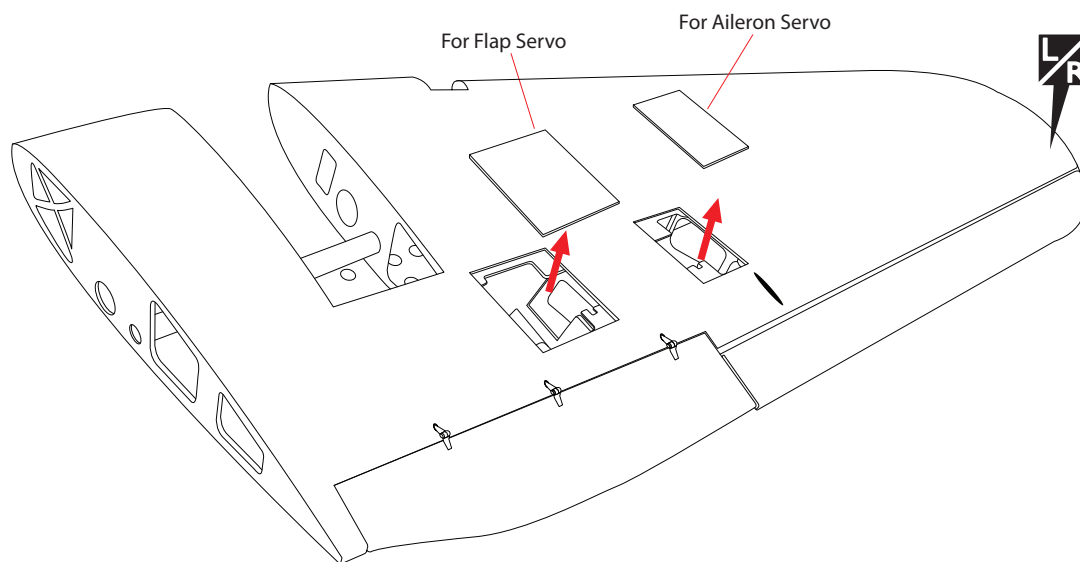

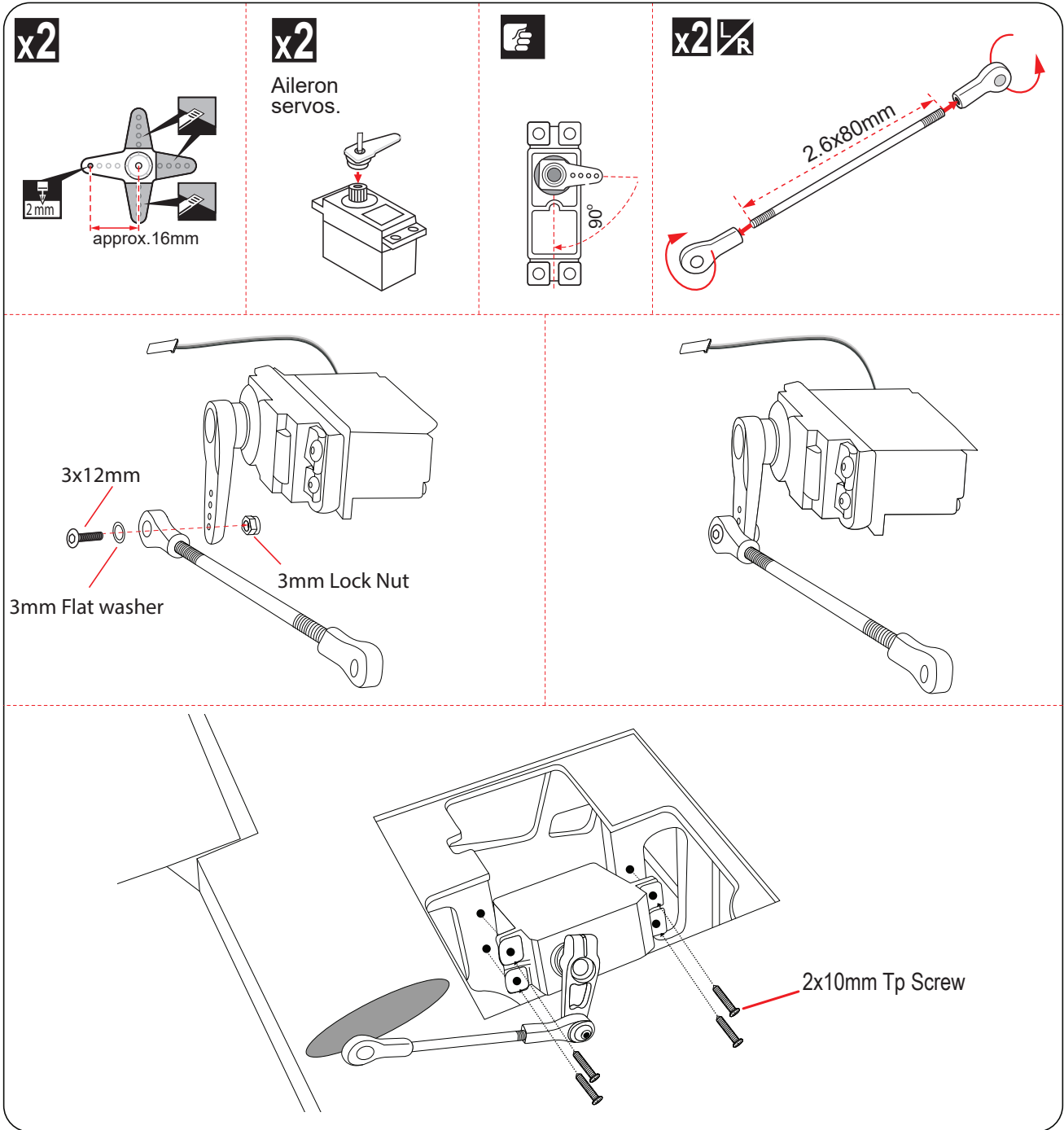

**x2** The number of times the same way Assembly (in this case twice).

Pay close attention here.

Cut off shaded portion carefully.

**L/R** Assemble left and right sides the same way.

x2

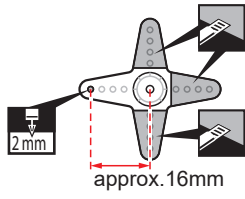

x2

Flaps servos.

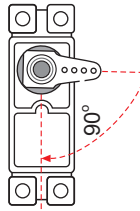
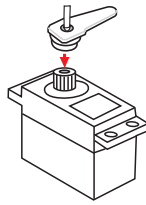

x2 L/R

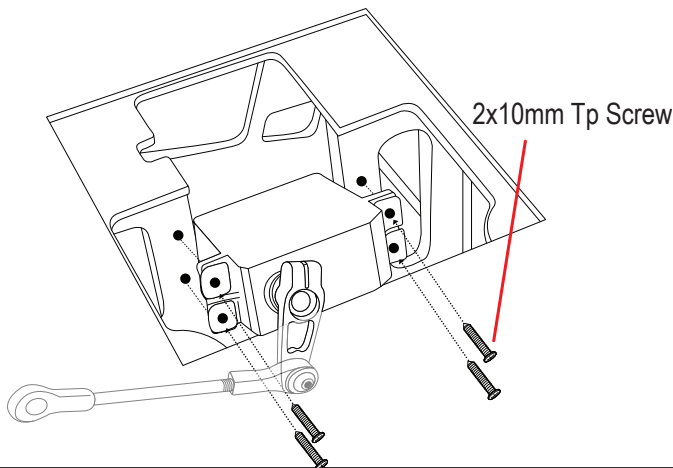
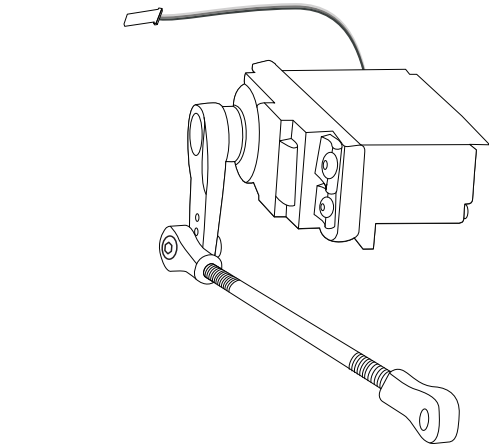
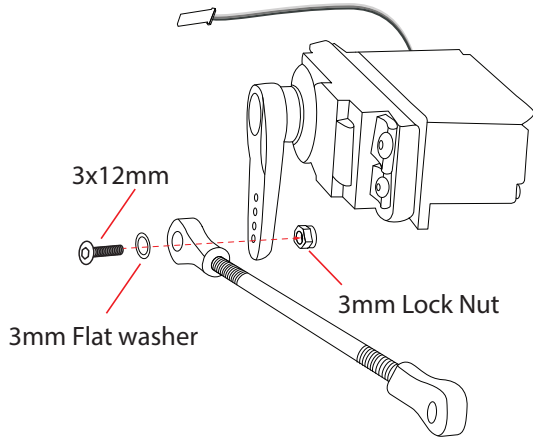
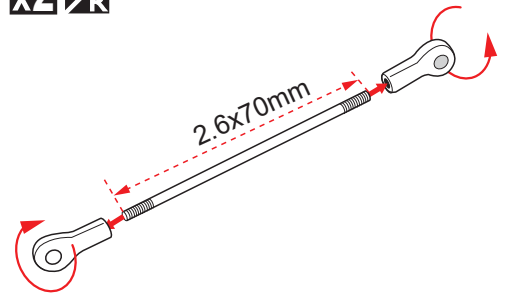

x2 L/R

3mm Lock Nut

3x12mm  
Button Head  
Cap Screw

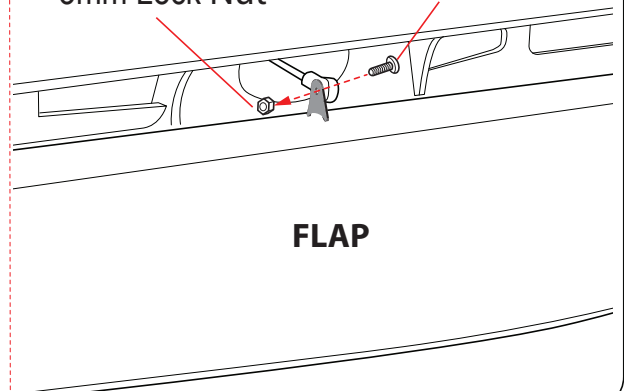

x2

The number of times the same way Assembly (in this case twice).



Pay close attention here.



Cut off shaded portion carefully.



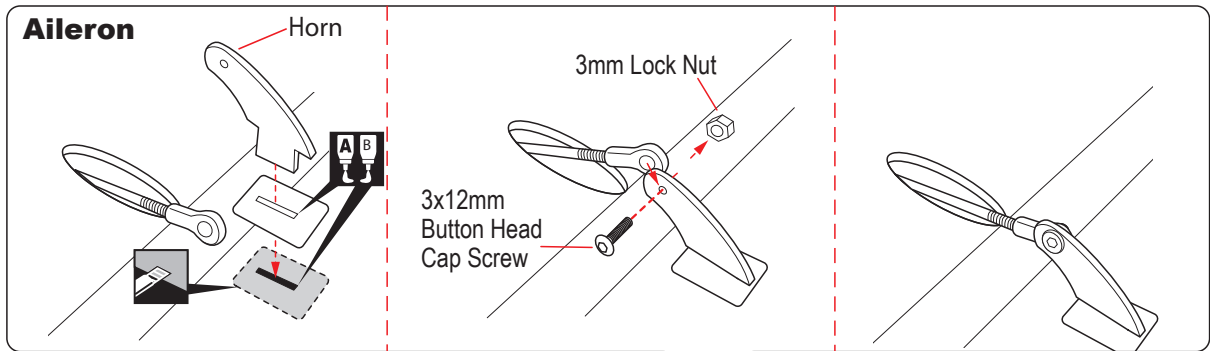
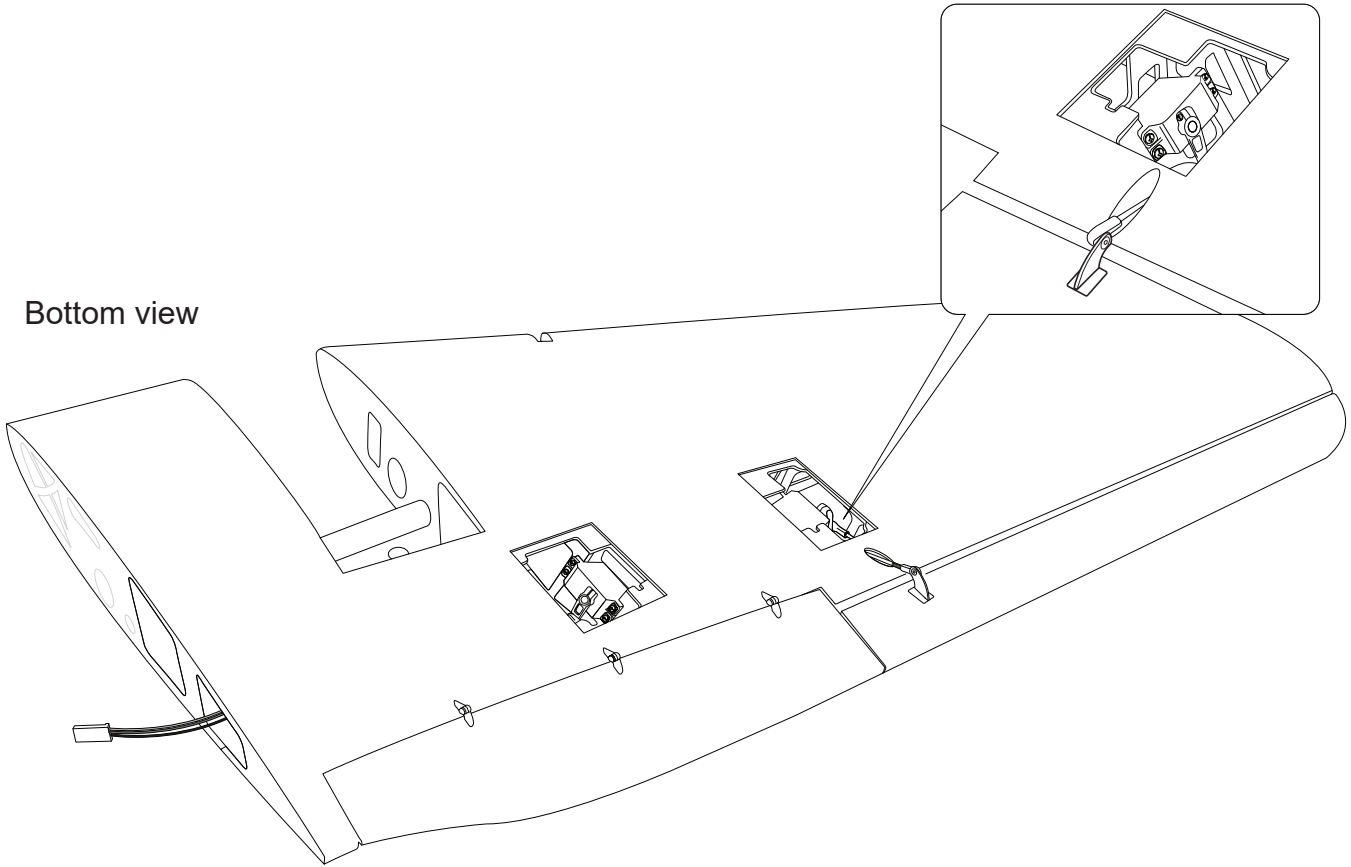

Assemble left and right sides the same way.

Bottom view

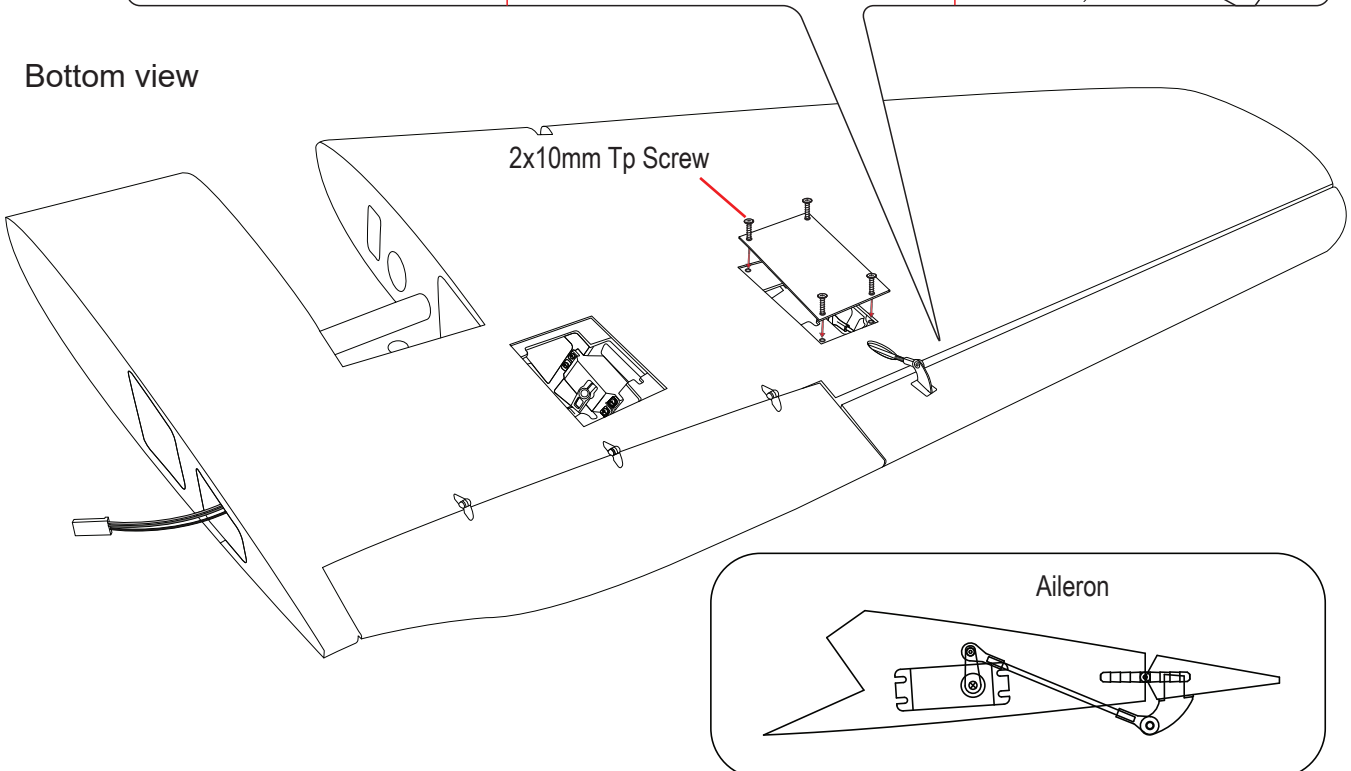

Bottom view



 Cut off shaded portion carefully.

 Apply epoxy glue.

Bottom view

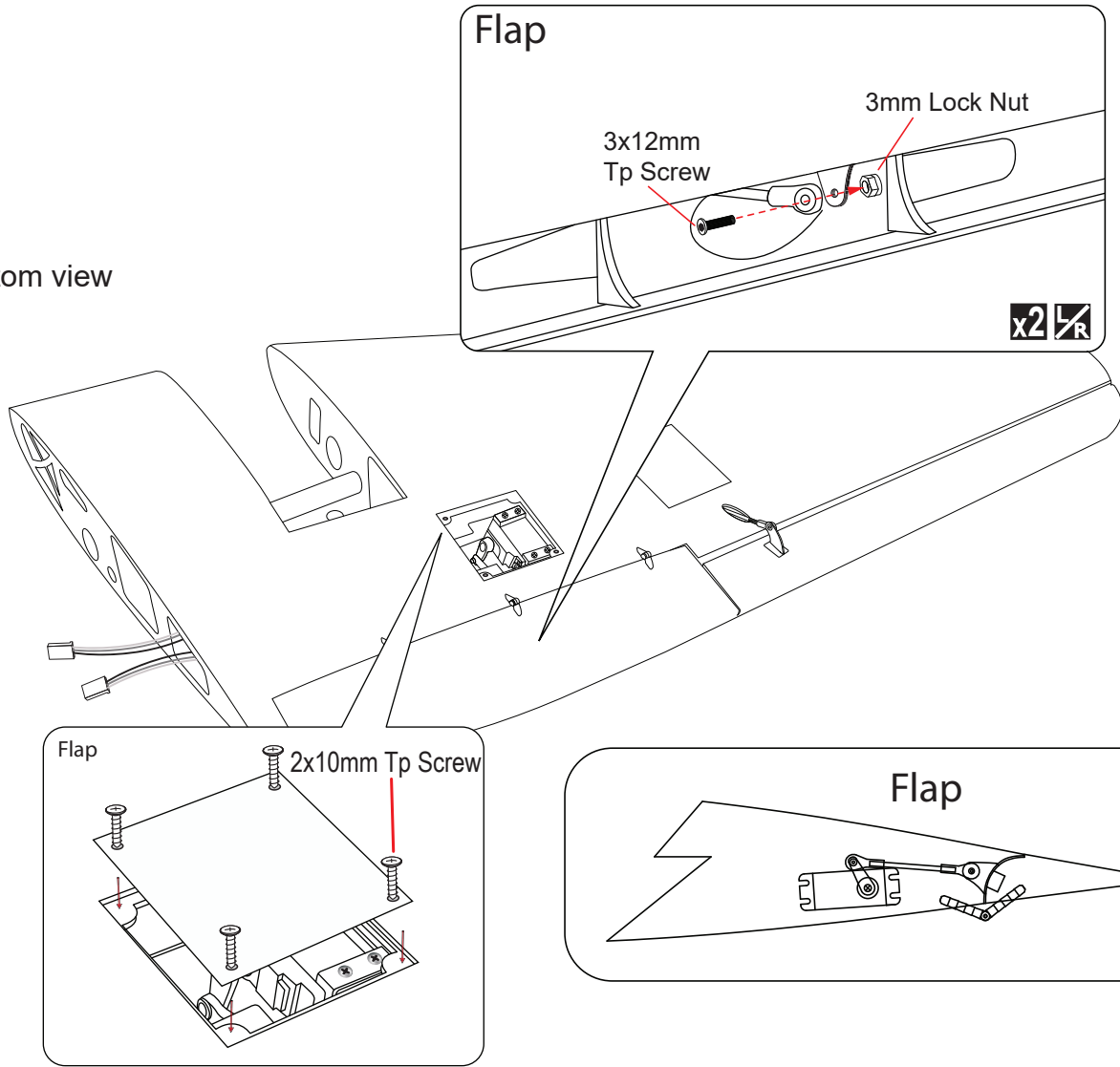

Bottom view

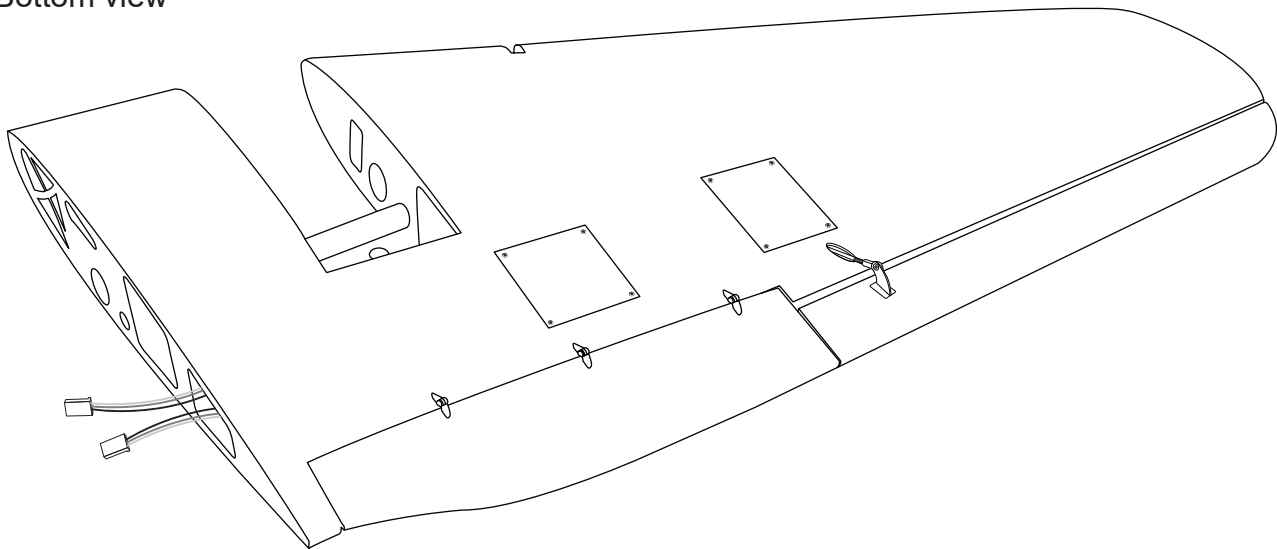

 Assemble left and right sides the same way.

 The number of times the same way Assembly (in this case twice).

**INSTALLING THE MOTOR MOUNT**

5x15mm Socket Head  
Cap Screw  
 -- 8

5x16mm Flat washer  
 --- 8

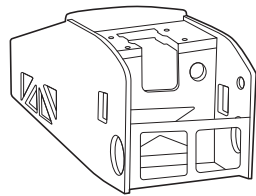

Bottom view

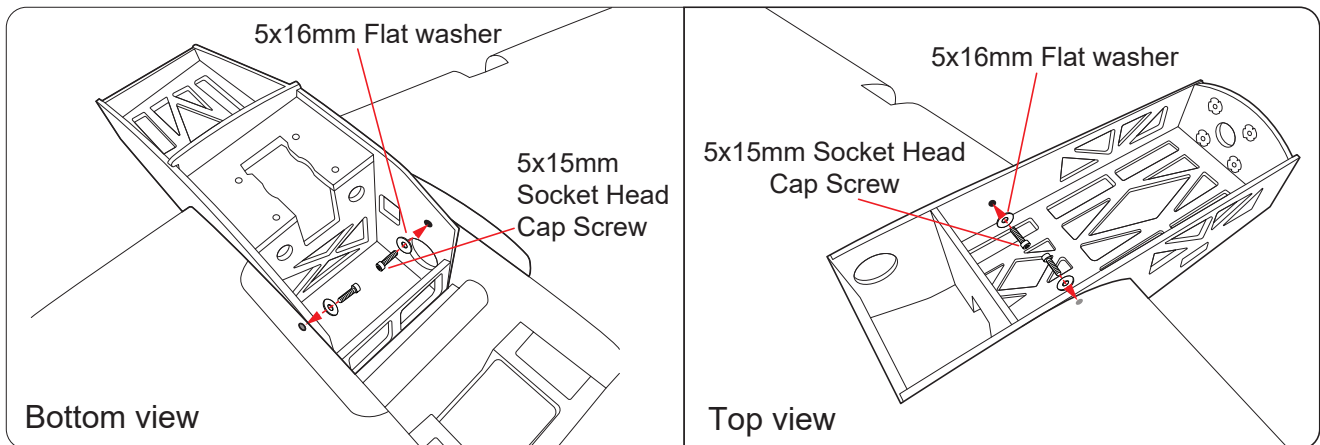
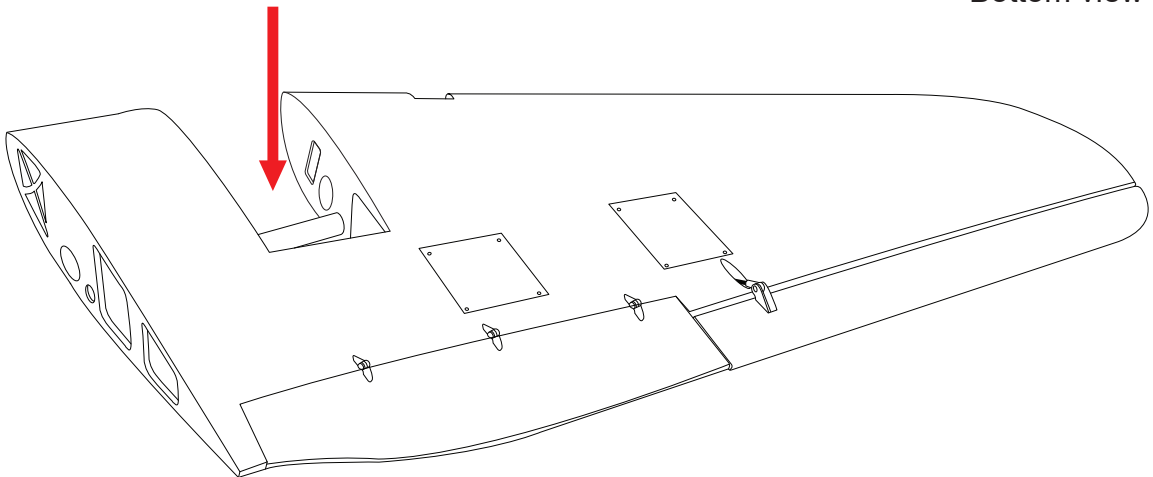

Bottom view

Top view

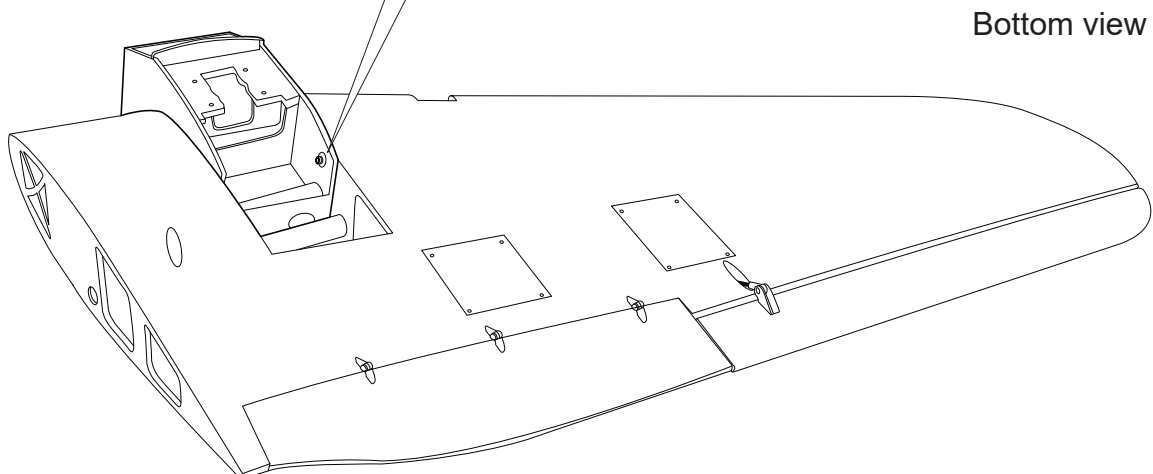

Bottom view

 Assemble left and right sides the same way.

# INSTALLING THE MAIN GEAR

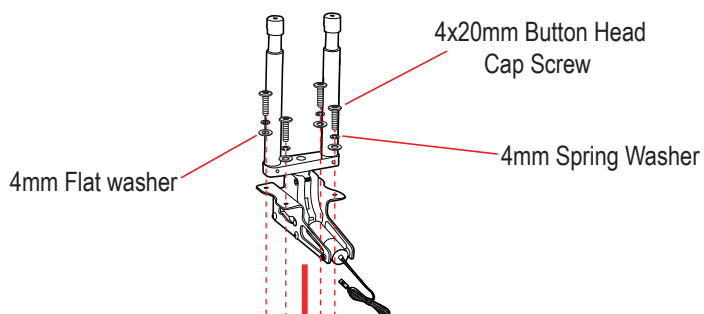
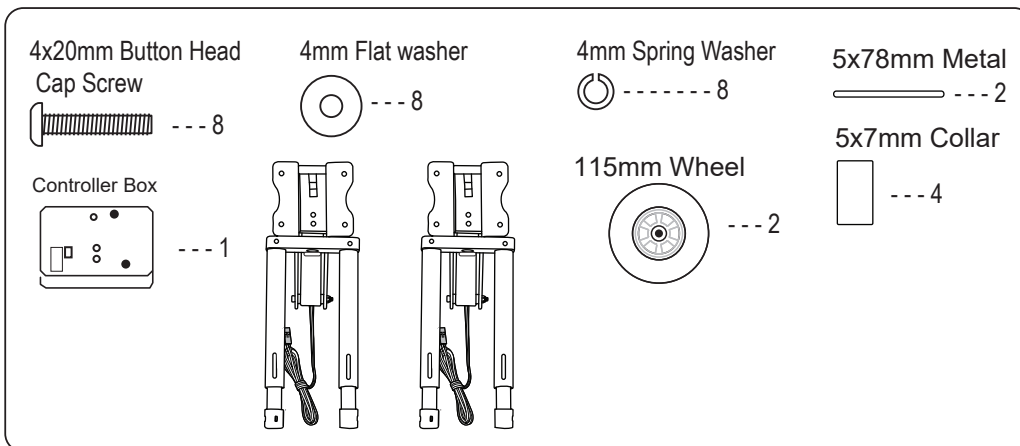

Bottom view

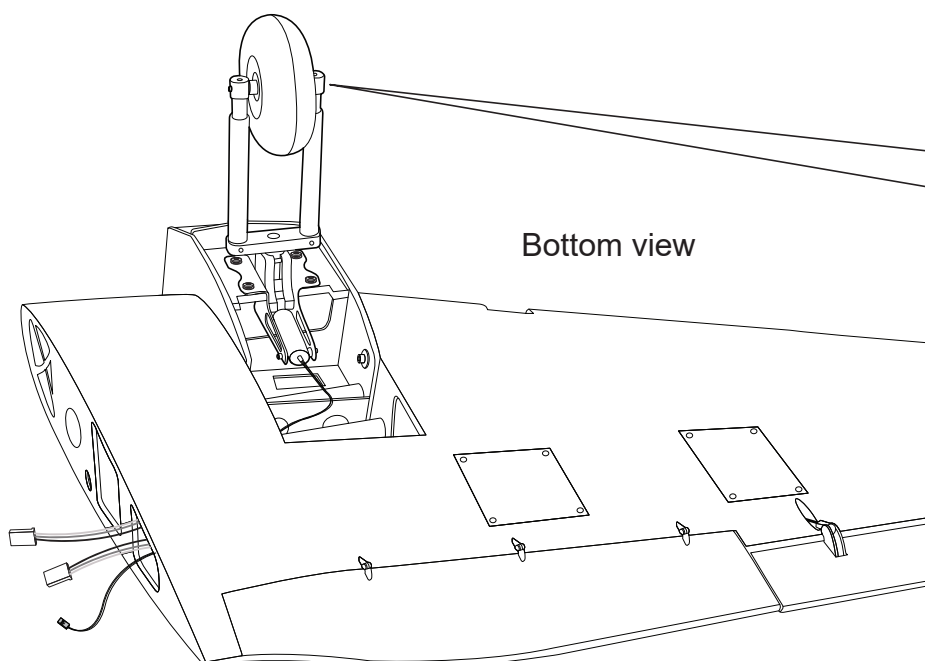
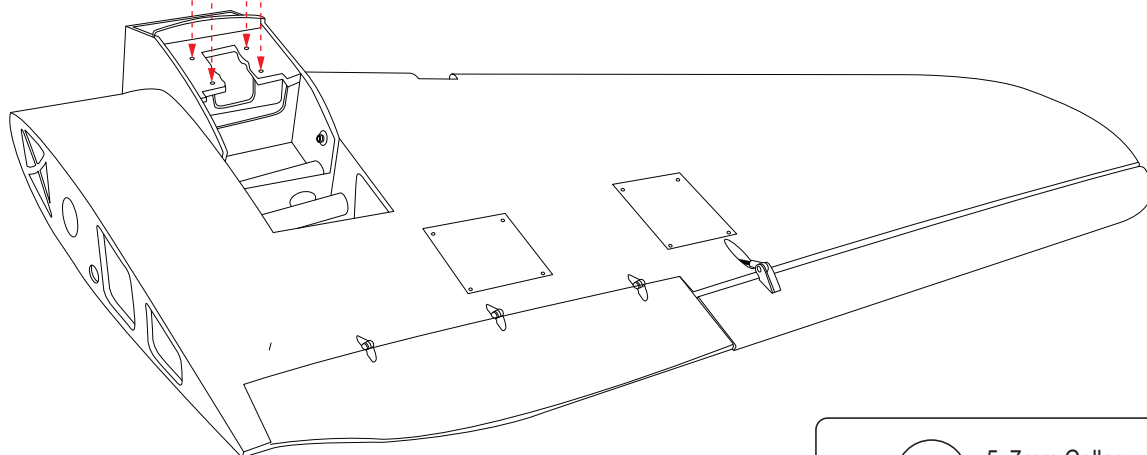

Bottom view

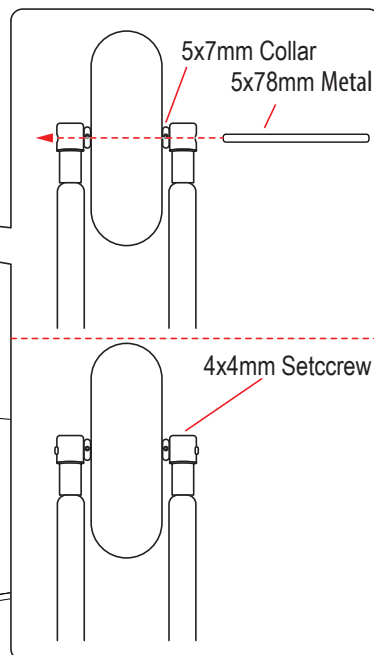

 Assemble left and right sides the same way.



### ELECTRIC RETRACT SYSTEM

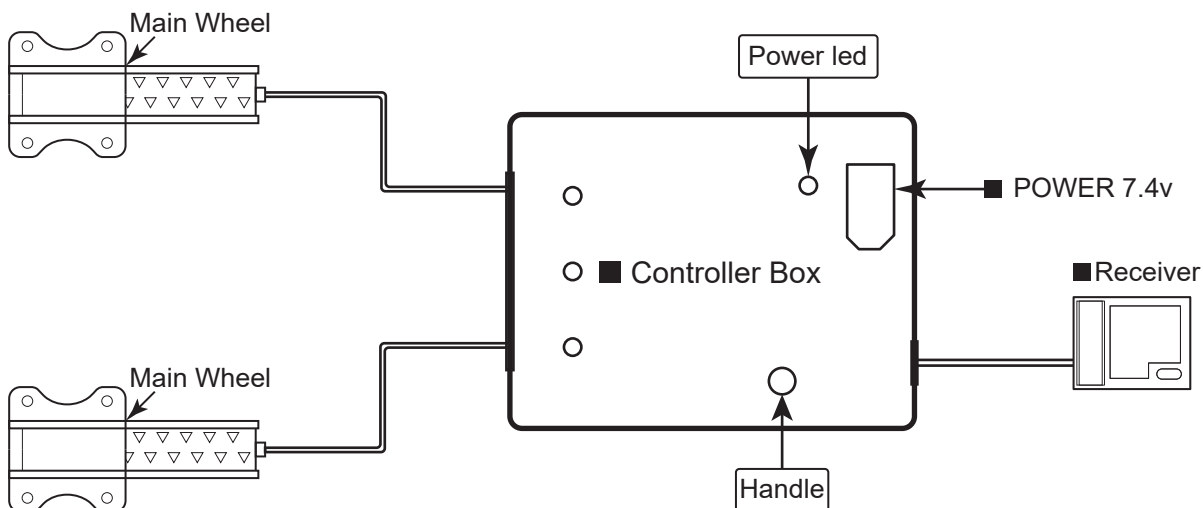

### INSTALLING THE MOTOR MOUNT

Using plate of plywood (supplied with the kit) mark the holes onto the fire wall for installing the motor mount for RIMFIRE-20CC

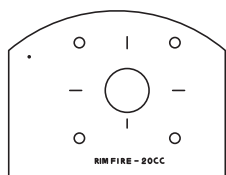

May be you also need to trim some wood from the tri-angle wood for the installation is easy.

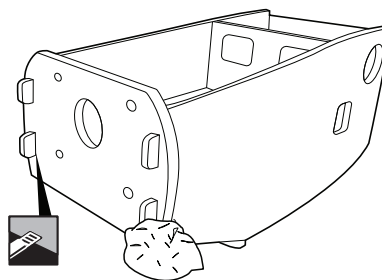



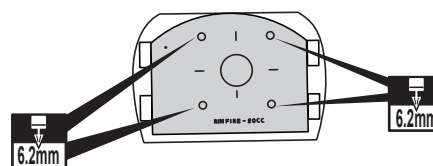
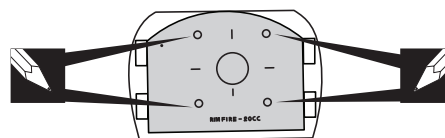
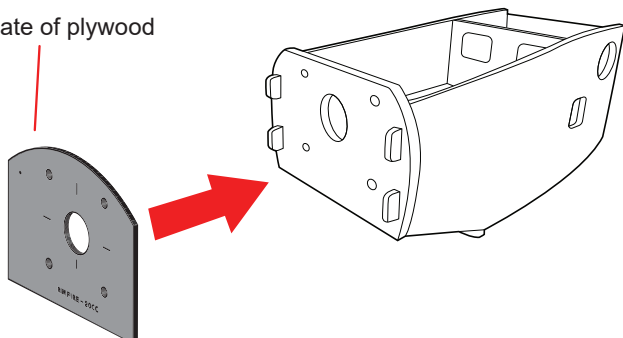

### RIMFIRE-20CC

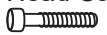

Plate of plywood



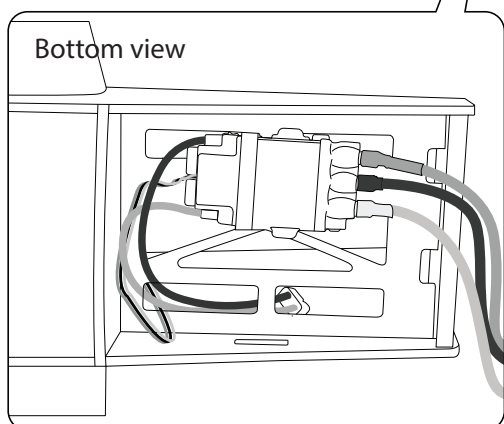
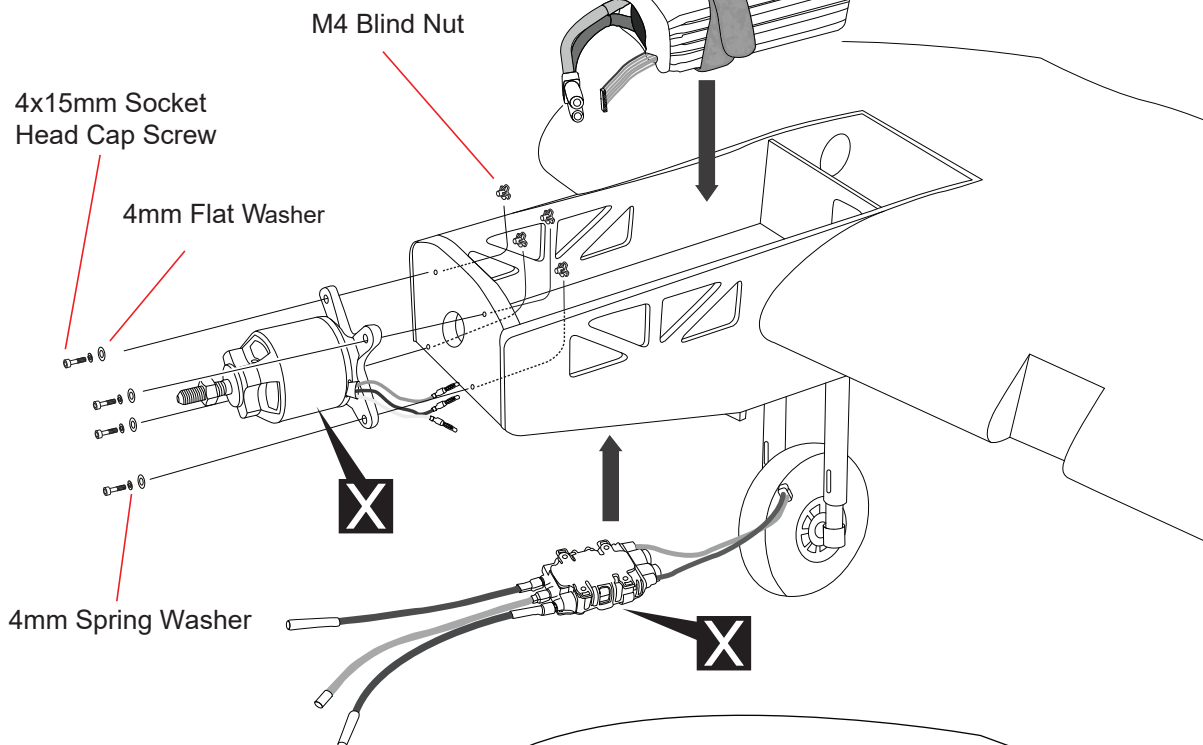

**INSTALLING THE ELECTRIC MOTOR (EP VERSION) AND BATTERY**

- |   |   |
|---|---|
| 4x15mm Socket Head Cap Screw  | M4 Blind Nut  |
|  ----- 8 |  ----- 8 |
| 4mm Flat Washer   | 4mm Spring Washer   |
|  ----- 8 |  ----- 8 |

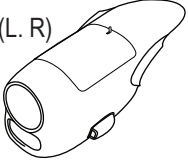

 Must be purchased separately!  
 Assemble left and right sides the same way.

**MOUNTING THE COWL**

(L, R)  ----- 2 pcs.      3x12mm TP Screw  ----- 10

Plastic Part (L,R)  ----- 4 pcs.

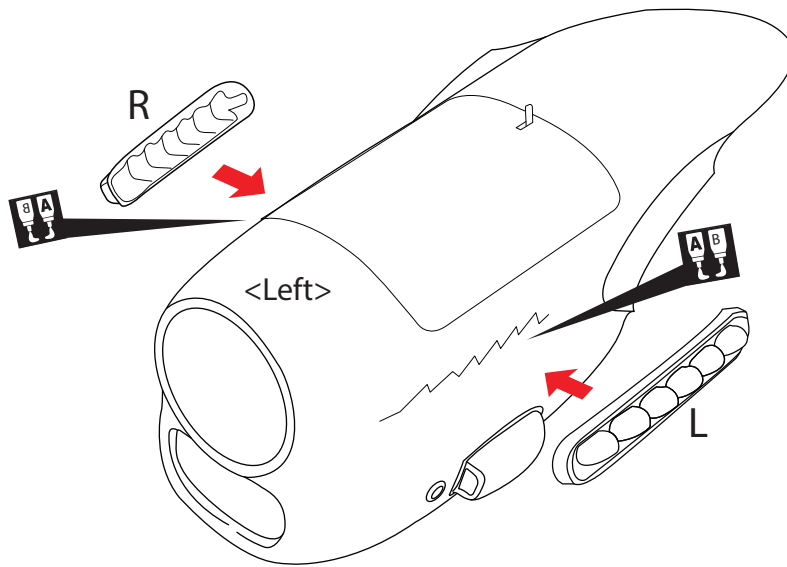

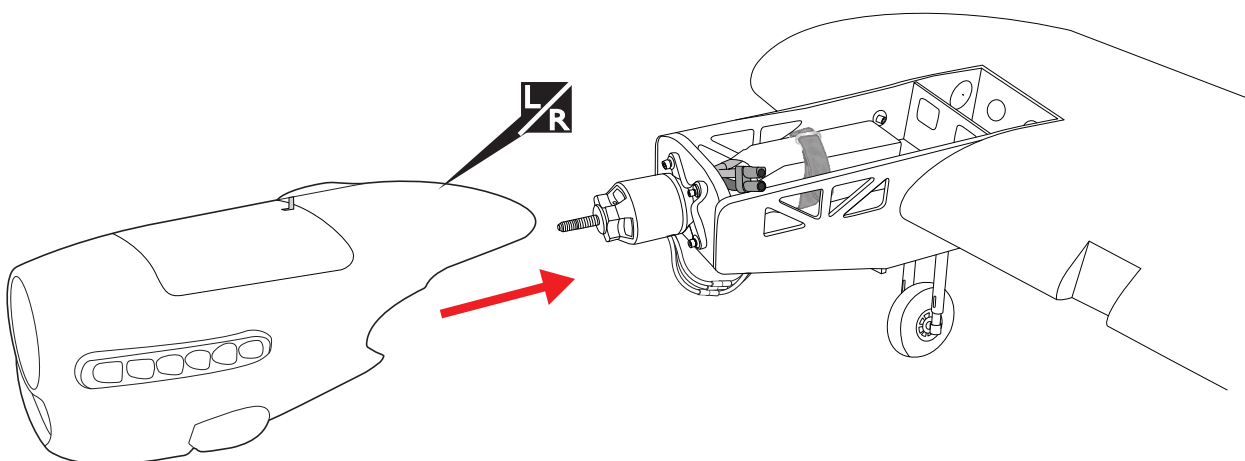

Top view

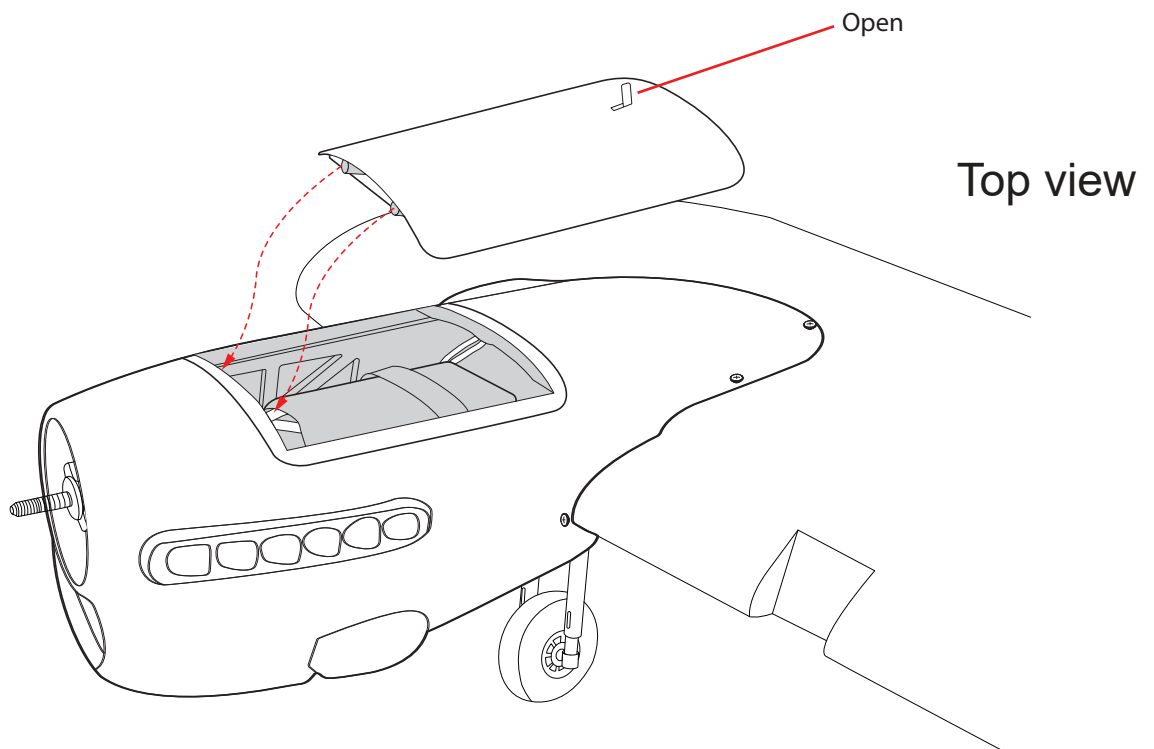
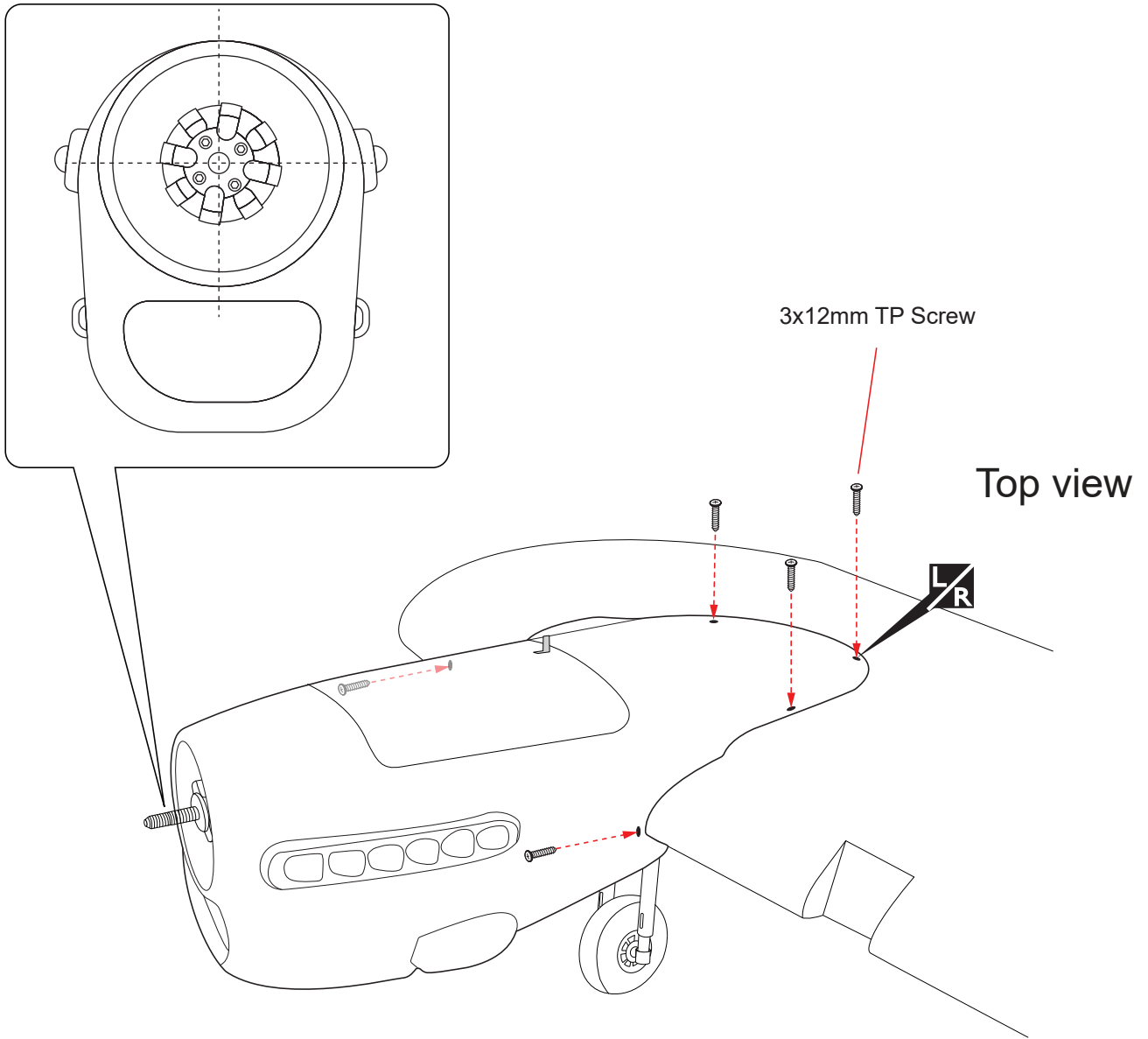

 Assemble left and right sides the same way.

 Apply epoxy glue.



 Assemble left and right sides the same way.

Top view

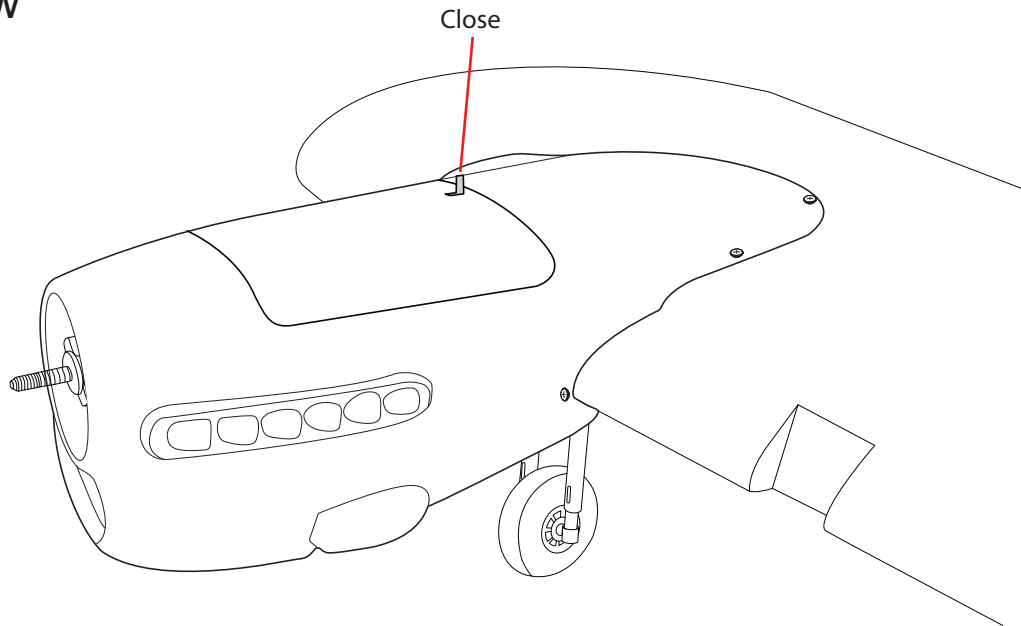

**INSTALLING THE SPINNER**

Install the spinner back-plate, propeller and spinner cone.

**!** *The propeller should not touch any part of the spinner cone. If it does, use a sharp modeling knife and carefully trim away the spinner cone where the propeller comes in contact with it.*





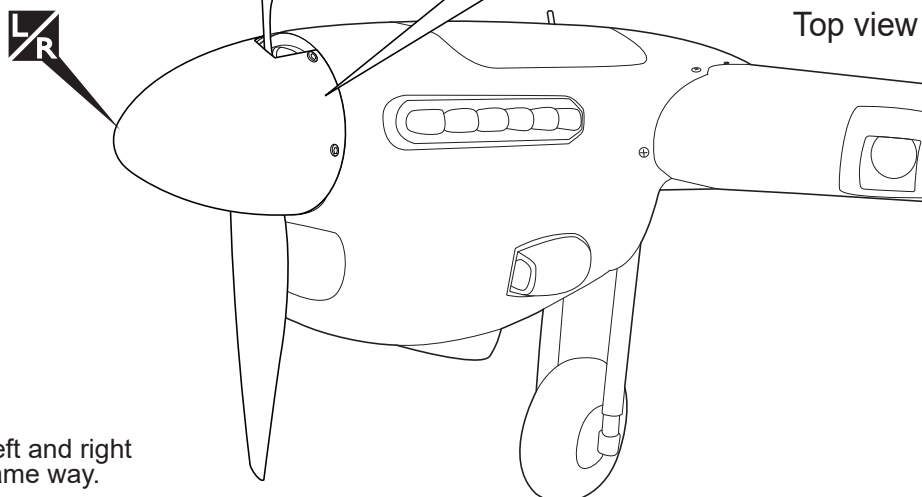
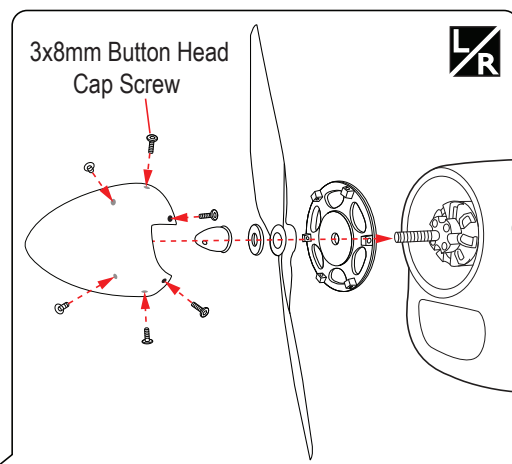
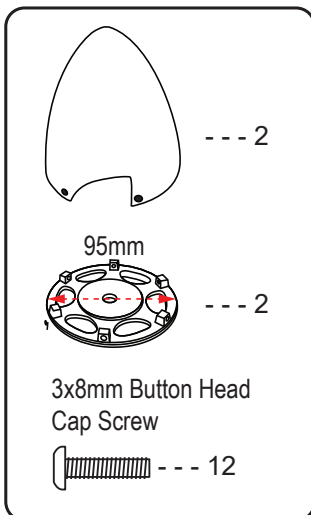









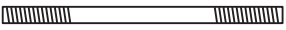

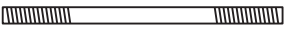

- ▶ Securely tighten the nut holding the propeller for it not come off when the motor is spinning. If coming off, there is a high risk of injury!
- ▶ Always ensure propeller and spinner are balanced. If unbalanced, vibration may result at high rotation and cause damage or injury.

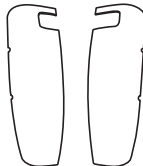
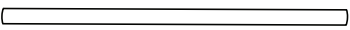

**LR** Assemble left and right sides the same way.

**INSTALLING THE GEAR DOOR**

67mm Pinned hinge  --- 8	3x12mm Button Head Cap Screw  --- 12	3mm Flat Washer  --- 16	 --- 6
2.6x50mm Push rod  -- 2	3x10mm Button Head Cap Screw  --- 16	3 x 12mm TP Screw  --- 10	Collar  --- 4
2.6x45mm Push rod  -- 4	3mm Lock Nut  --- 22	 --- 8	
Ball link  --- 12	Gear Door (L.R)  --- 4 pcs.	6x136mm Aluminium  --- 2	
3x12mm TP Screw  --- 6		4x4mm Set Screw  --- 6	
L.R  --- 2 pcs.		3x4mm Set Screw  --- 4	

Bottom view

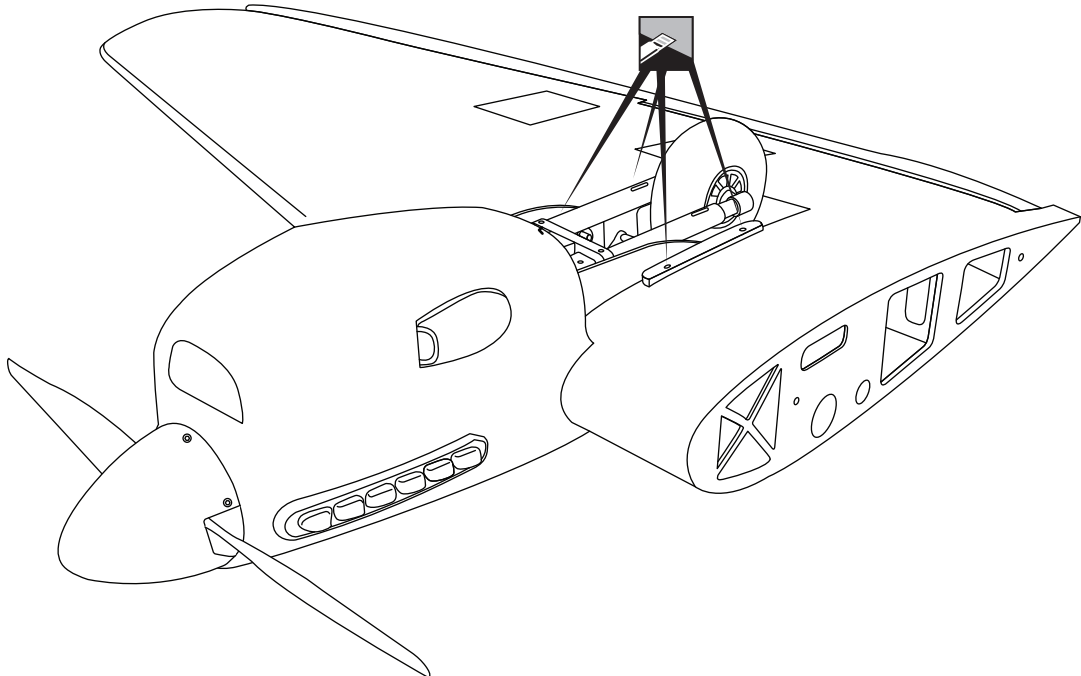

Bottom view

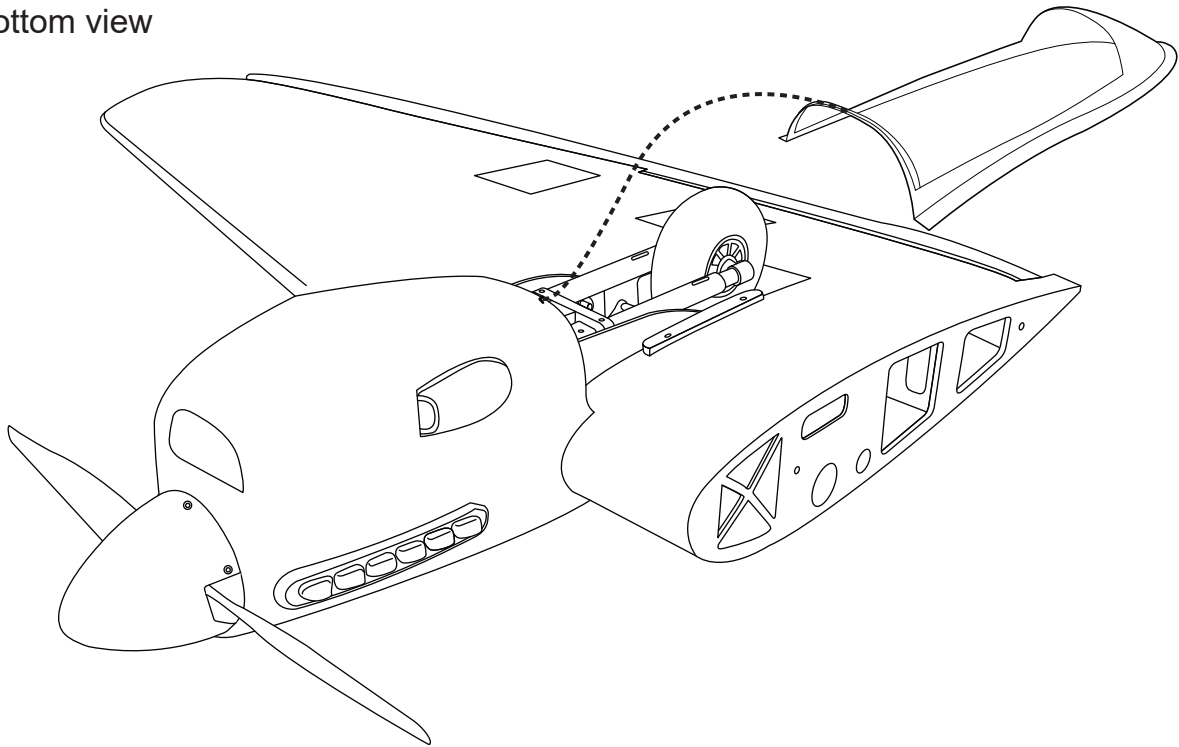

Bottom view

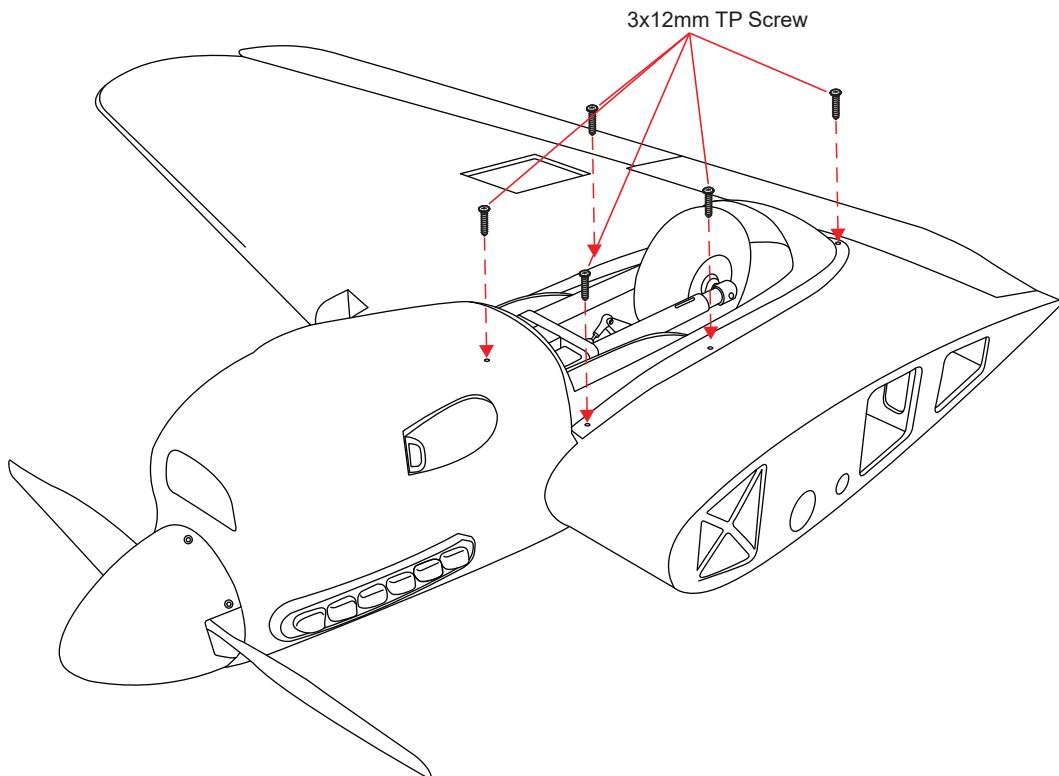

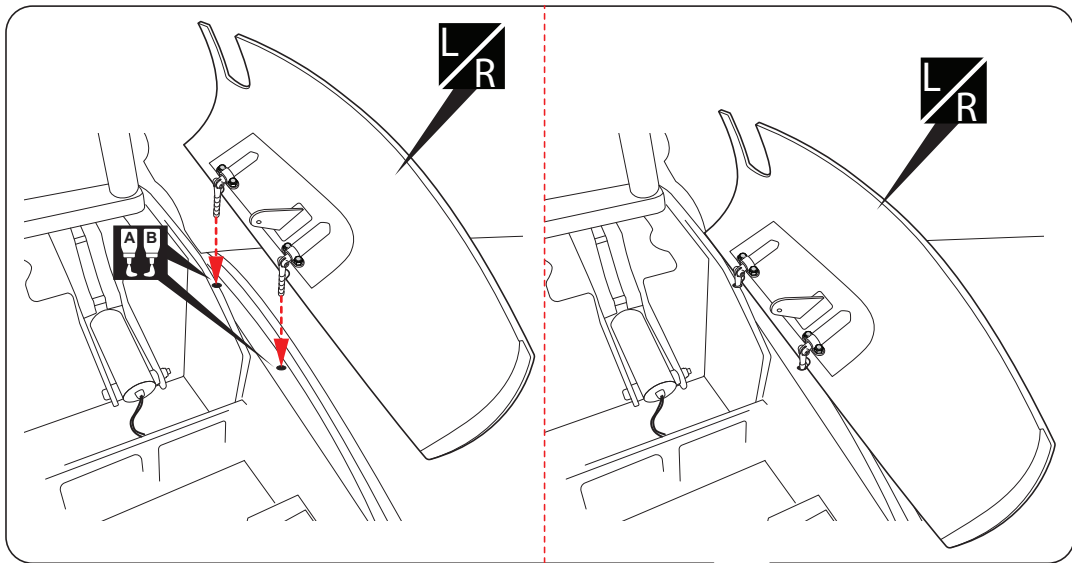
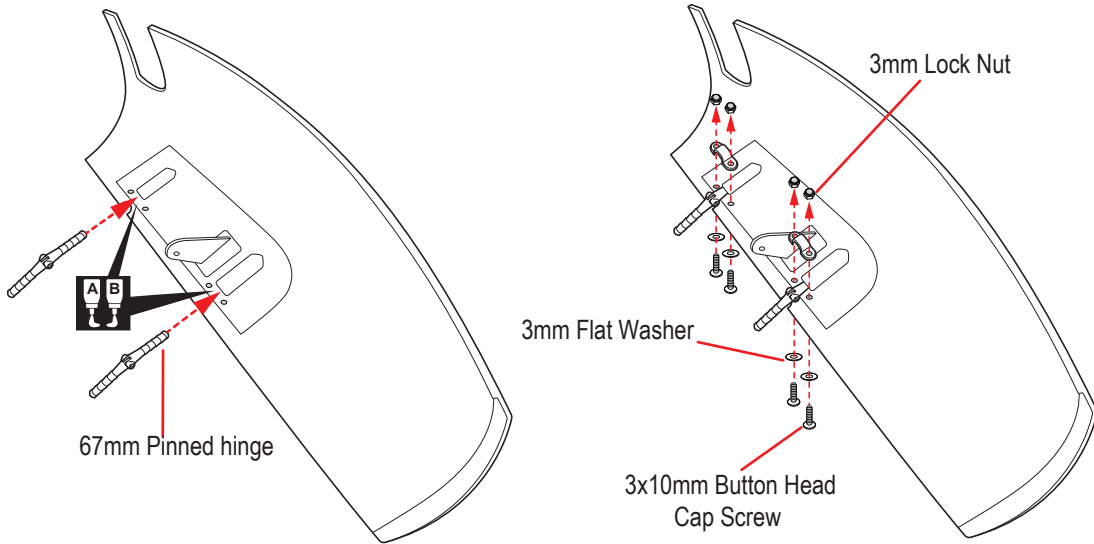

Bottom view

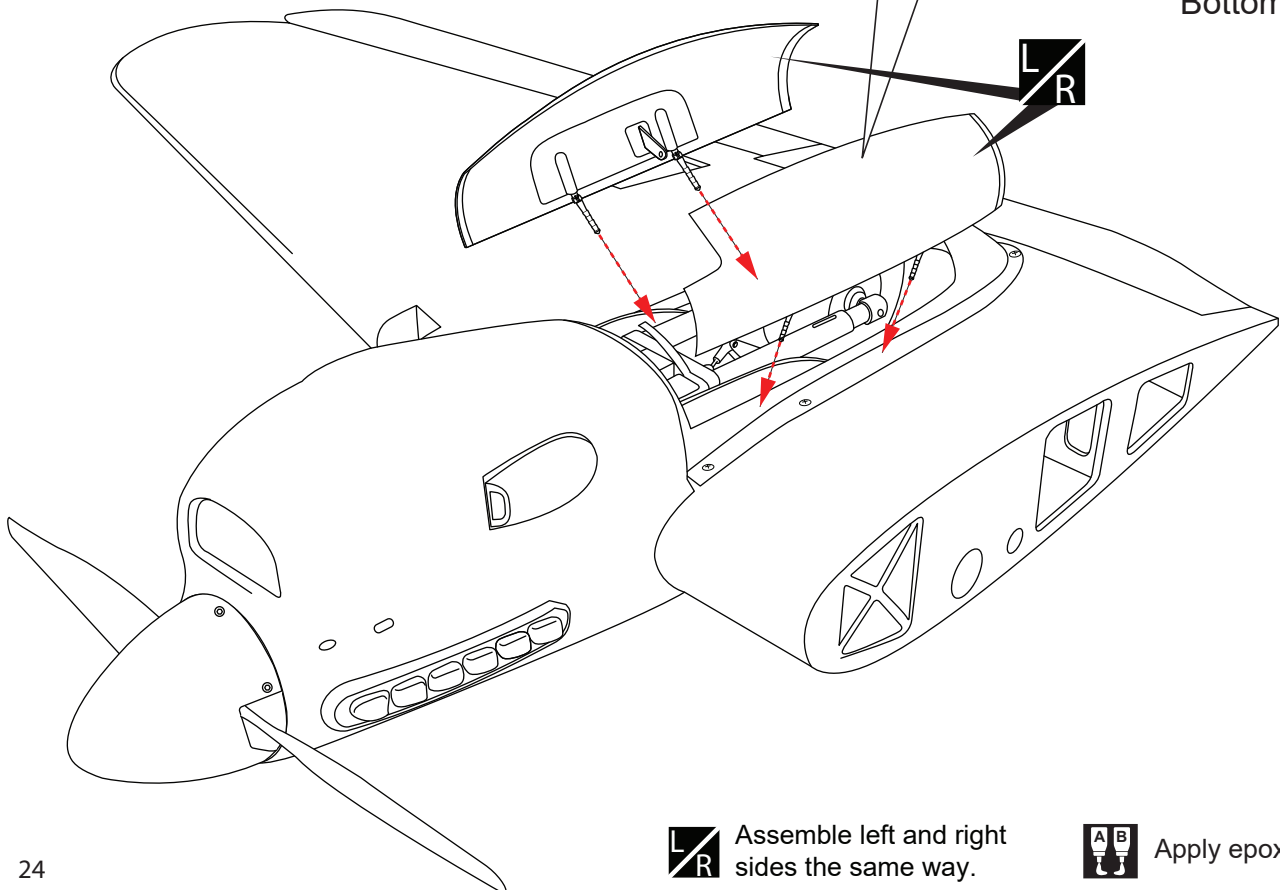



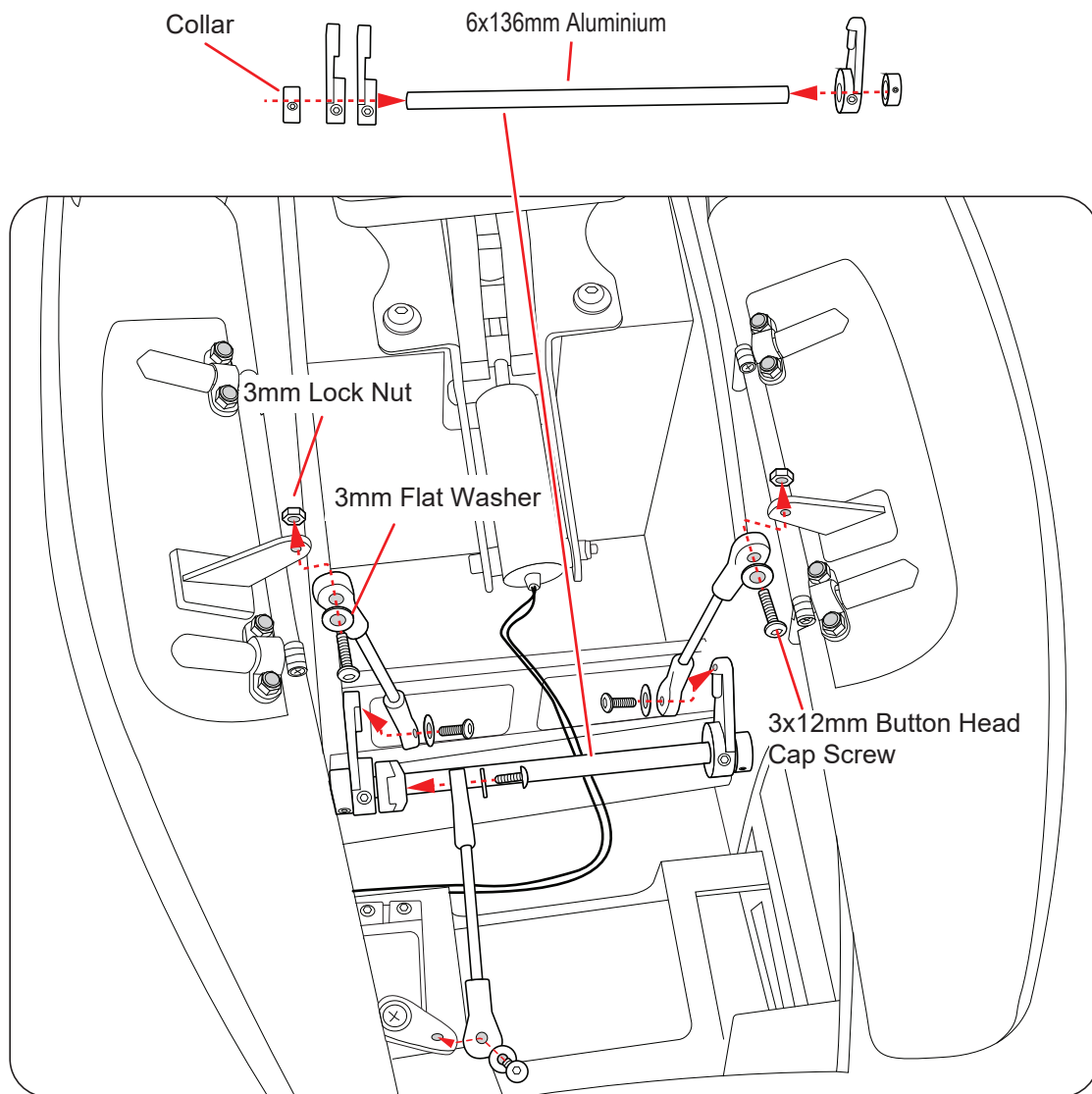

Bottom view

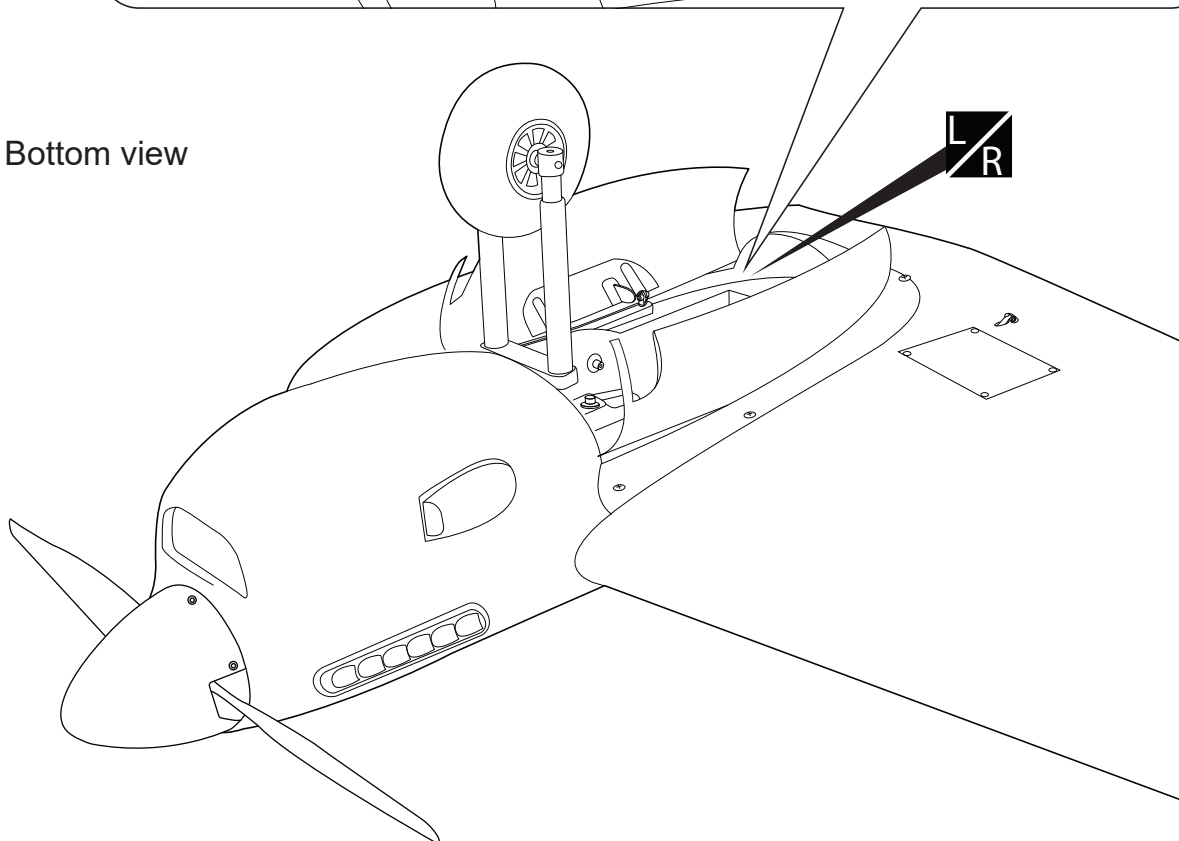

 Assemble left and right sides the same way.

Bottom view

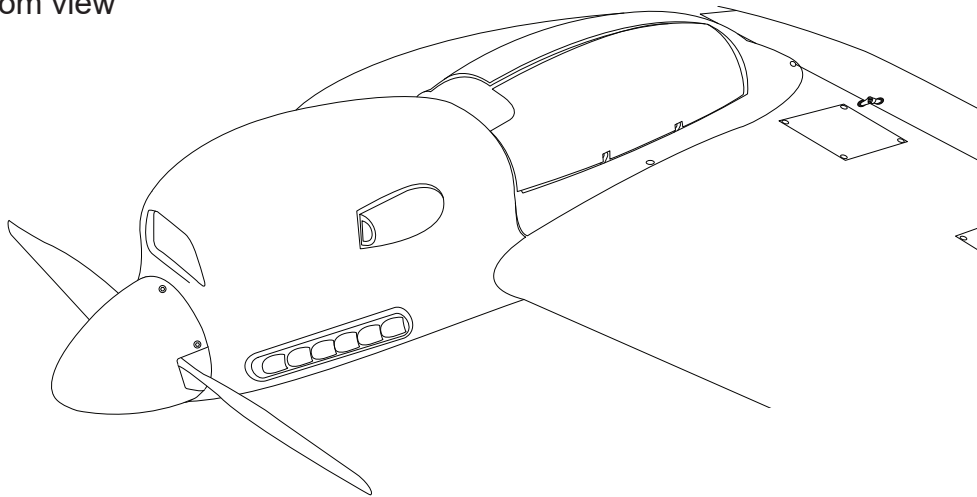

### INSTALLING THE WING PLASTIC LIGHT

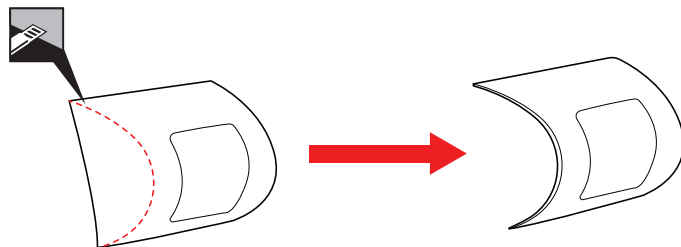
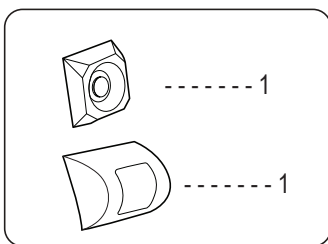

Top view

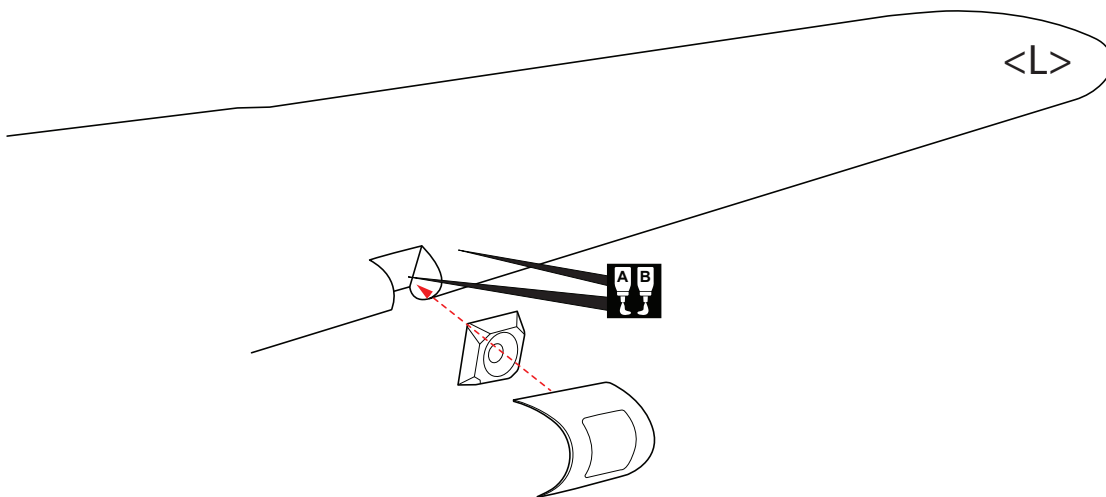

Top view

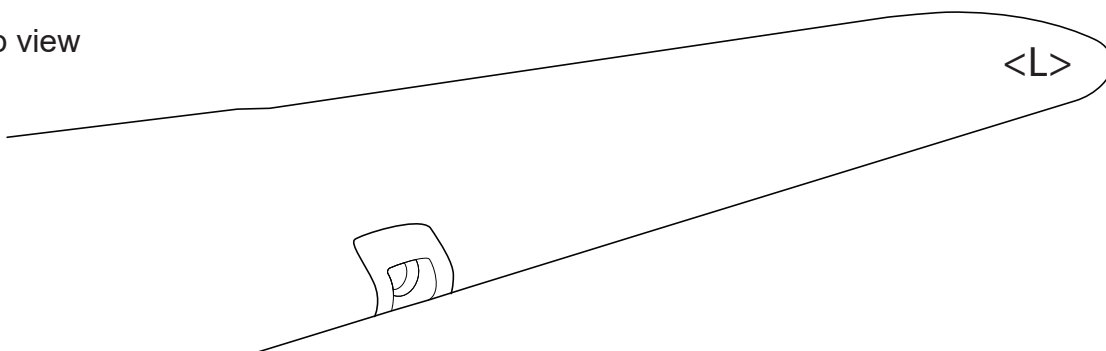

# INSTALLING THE FUSELAGE SERVOS

1) Install the rubber grommets and brass collets into the elevator, rudder and throttle servo. Test fit the servos into the servo tray. Trim the tray if necessary to fit your servos.

2) Mount the servo to the tray using the mounting screws provided with your radio system.

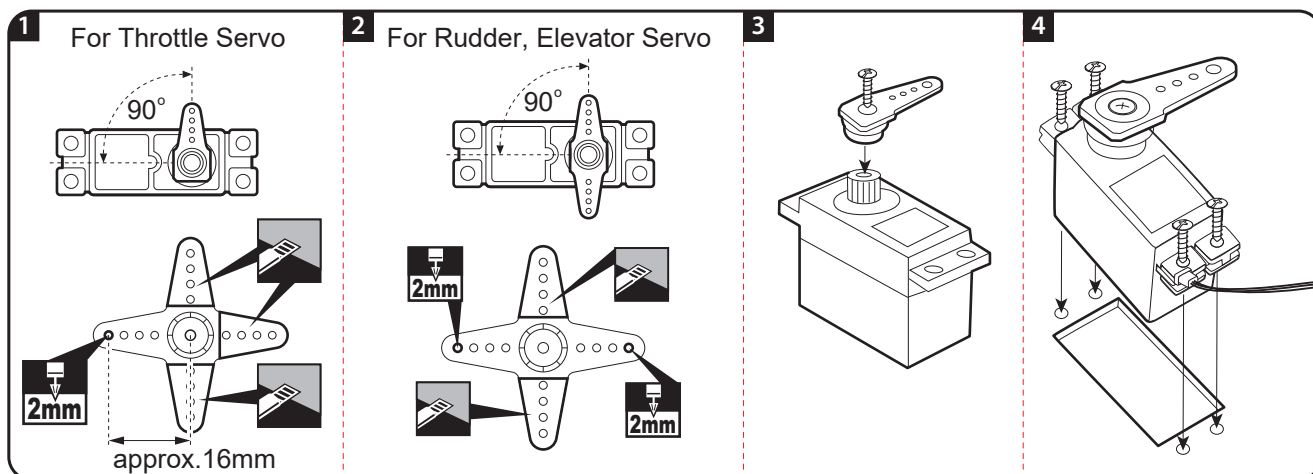
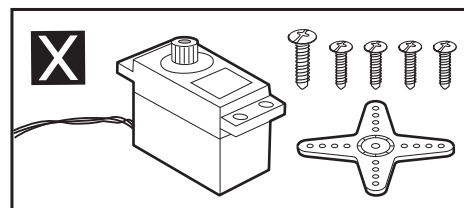

Top view

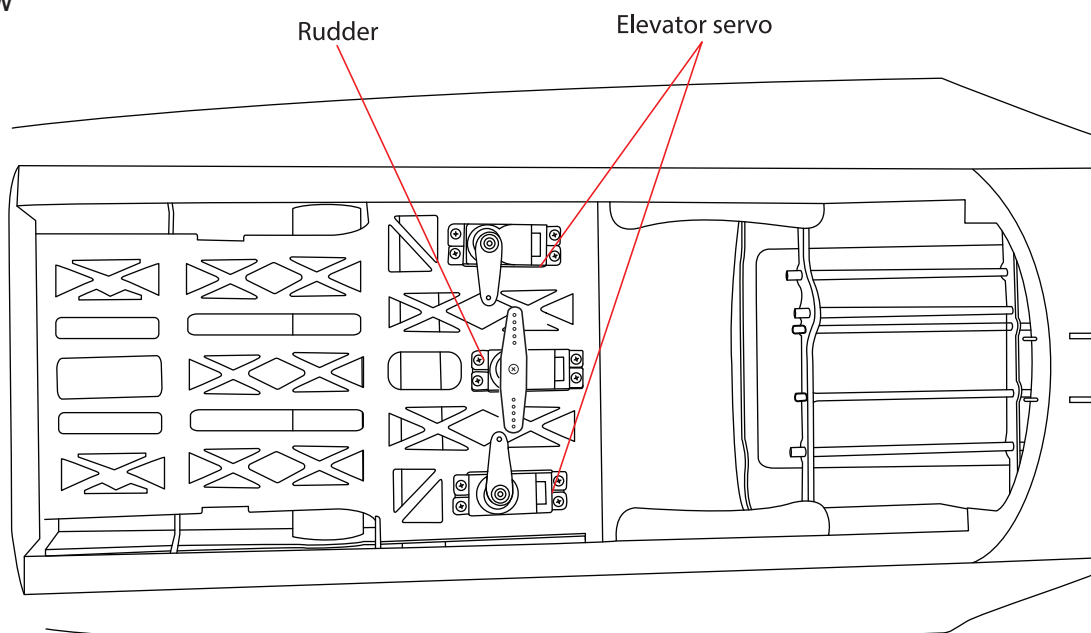

Cut off shaded portion carefully.

Must be purchased separately!

Drill holes using the stated (in this case 2mm ø).

**INSTALLING HORIZONTAL STABILIZER**

1. Using a modeling knife, cut away the covering from the fuselage for the stabilizer and remove it.
  2. Remove the covering from the stabilizer.
-  *When cutting through the covering to remove it, cut with only enough pressure to only cut through the covering it's self. Cutting into the balsa structure may weaken it. This could lead to possible failure during flight.*
3. Attach the wing to the fuselage as picture.
  4. Test the position of the elevator and adjust it as shown.

5. When you are sure that everything is aligned correctly, mix up a generous amount of 30 minute epoxy. Apply a thin layer to the bottom and to the top of the stabilizer mounting area and to the stabilizer mounting platform sides in the fuselage. Insert the stabilizer in place and re-align. Double check all of your measurements one more time before the epoxy cures. Remove any excess epoxy using a paper towel and rubbing alcohol and hold the stabilizer in place with T-pins or masking tape.
6. After the epoxy has fully cured, remove the masking tape or T-pins used to hold the stabilizer in place and carefully inspect the glue joints. Use more epoxy to fill in any gaps that were not filled previously and clean up the excess using a paper towel and rubbing alcohol.

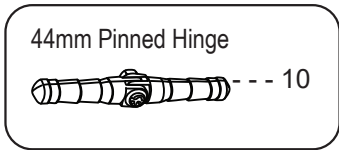

7. Repeat step 1 - step 2 from the installing aileron for the installing elevator.

Top view

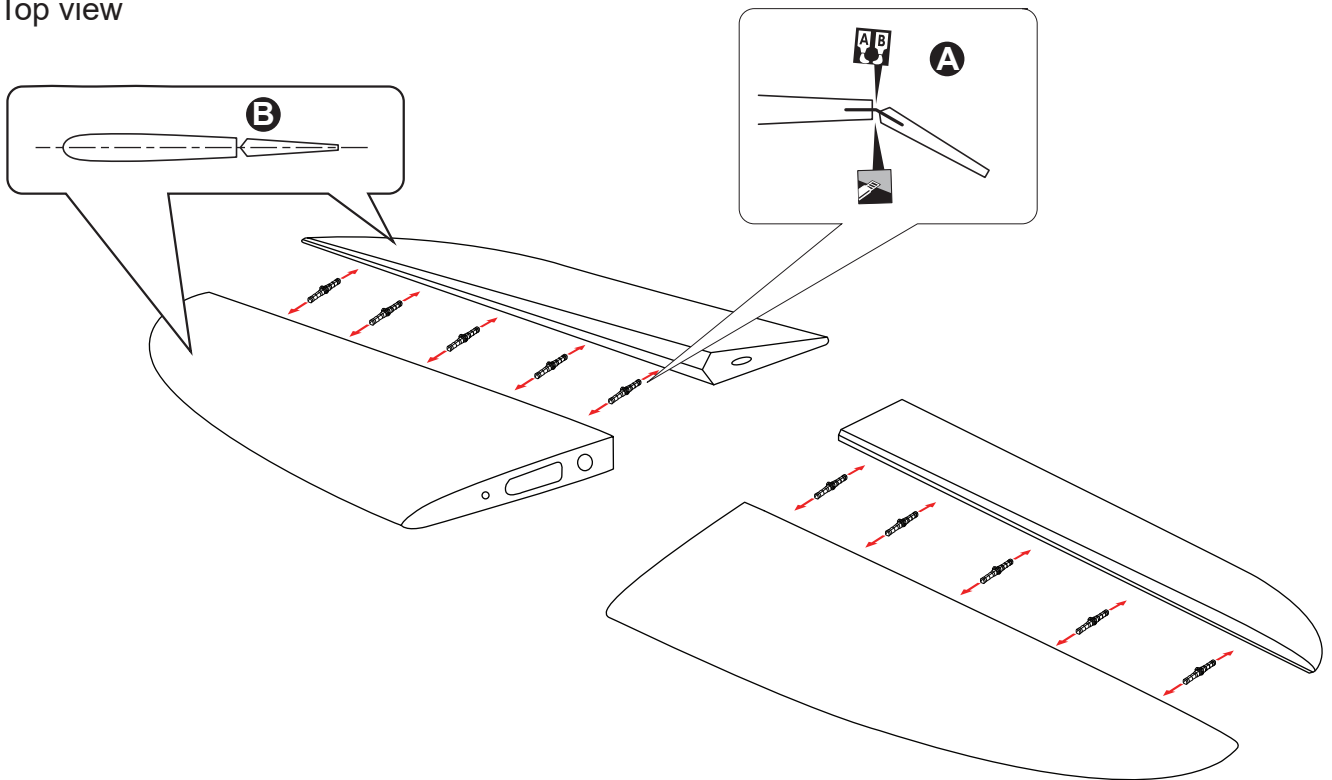

► Make certain plane is aligned accurately per the diagram. A mis-aligned plane can fly erratically and cause accidents.

- A** Secure nylon hinges with instant glue, being careful horizontal fin and elevator.
- B** Align the center line of horizontal fin with elevator.

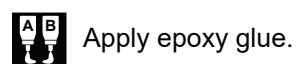
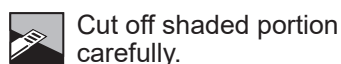

340mm  $\varnothing$  12 Aluminium

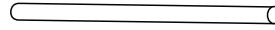

----- 1

Top view

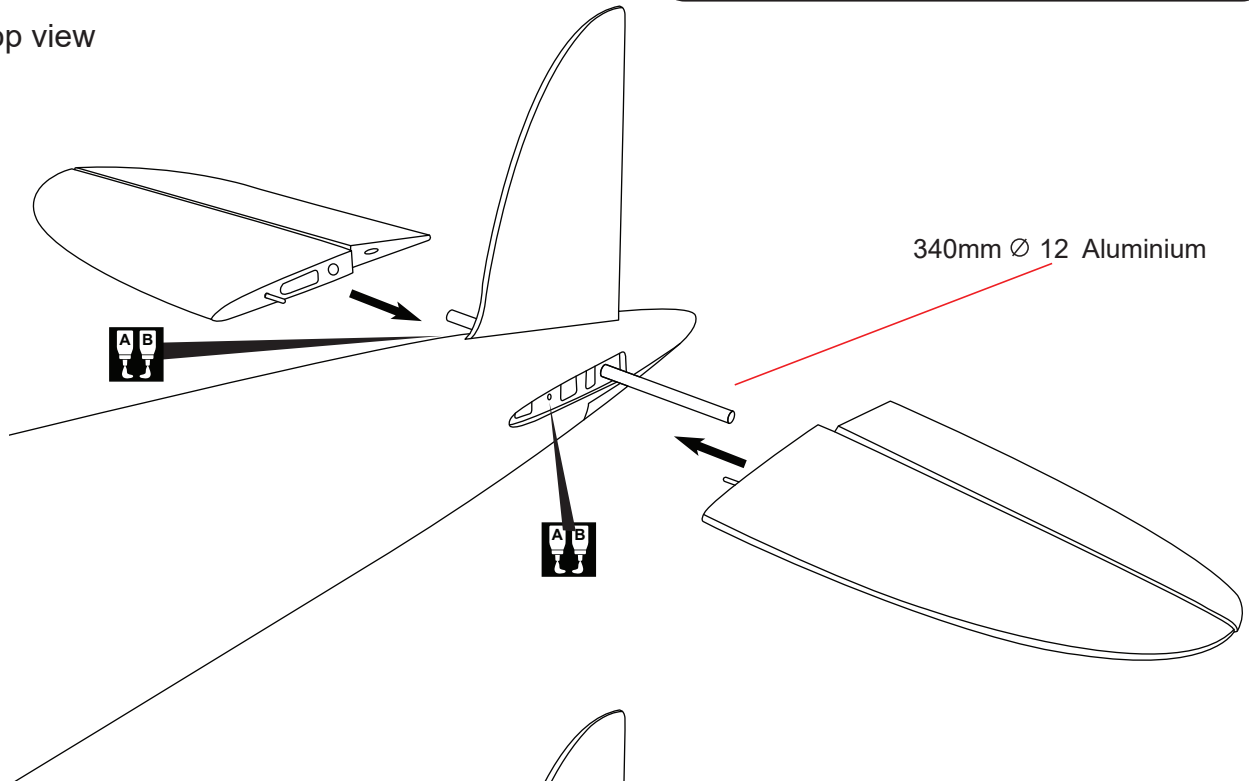



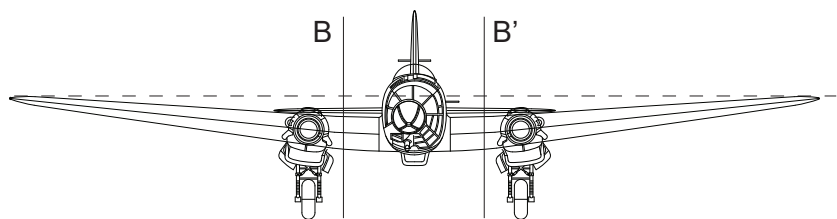
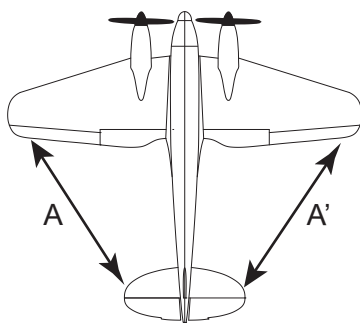
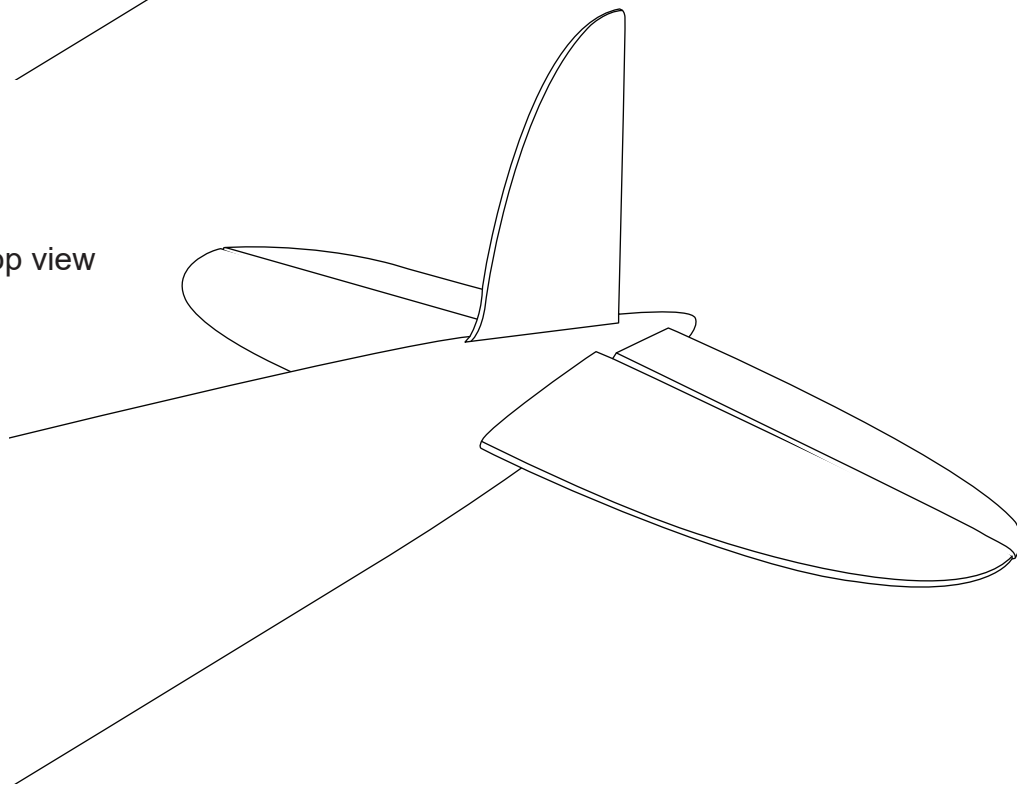



Top view

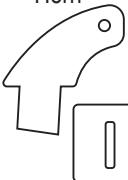

A = A'  
B = B'

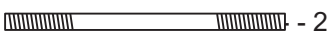

Apply epoxy glue.

 Horn --- 2	 Ball link --- 4	 3x12mm Button Head Cap Screw --- 4	 3mm Flat Washer ---- 4
 --- 2	 2.6x1140mm Push rod - 2	 3mm Lock Nut --- 4	

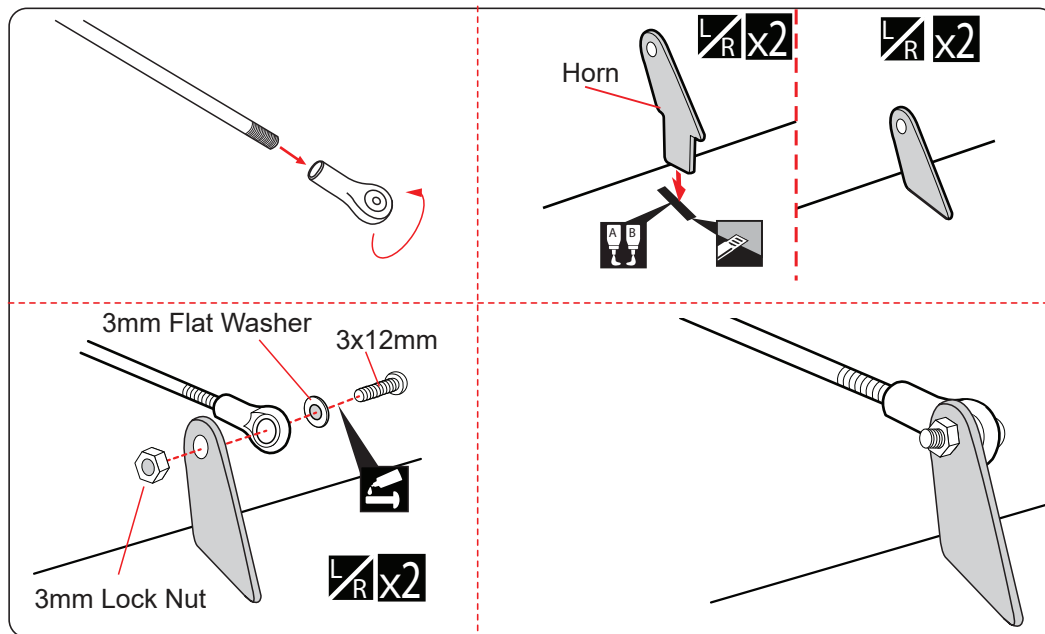

Bottom view

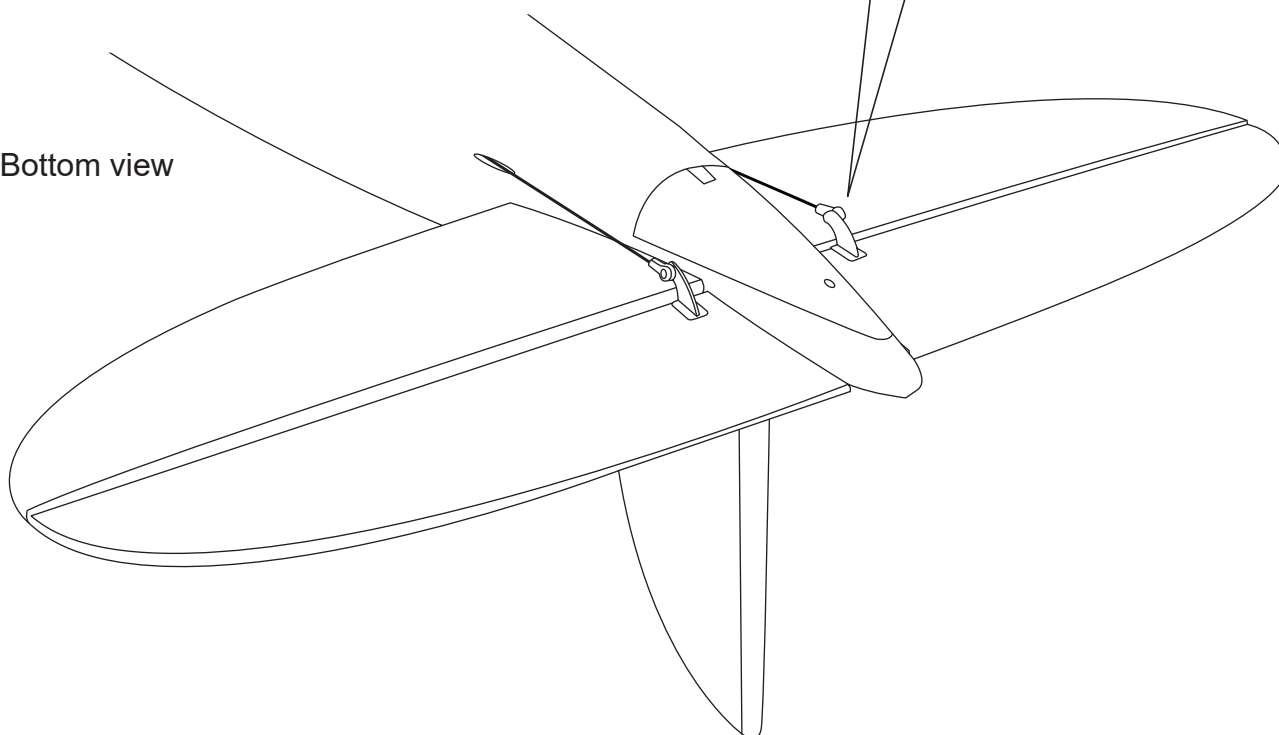

Apply epoxy glue.



The number of times the same way Assembly (in this case twice).



Apply threadlocker (screw cement).



Assemble left and right sides the same way.





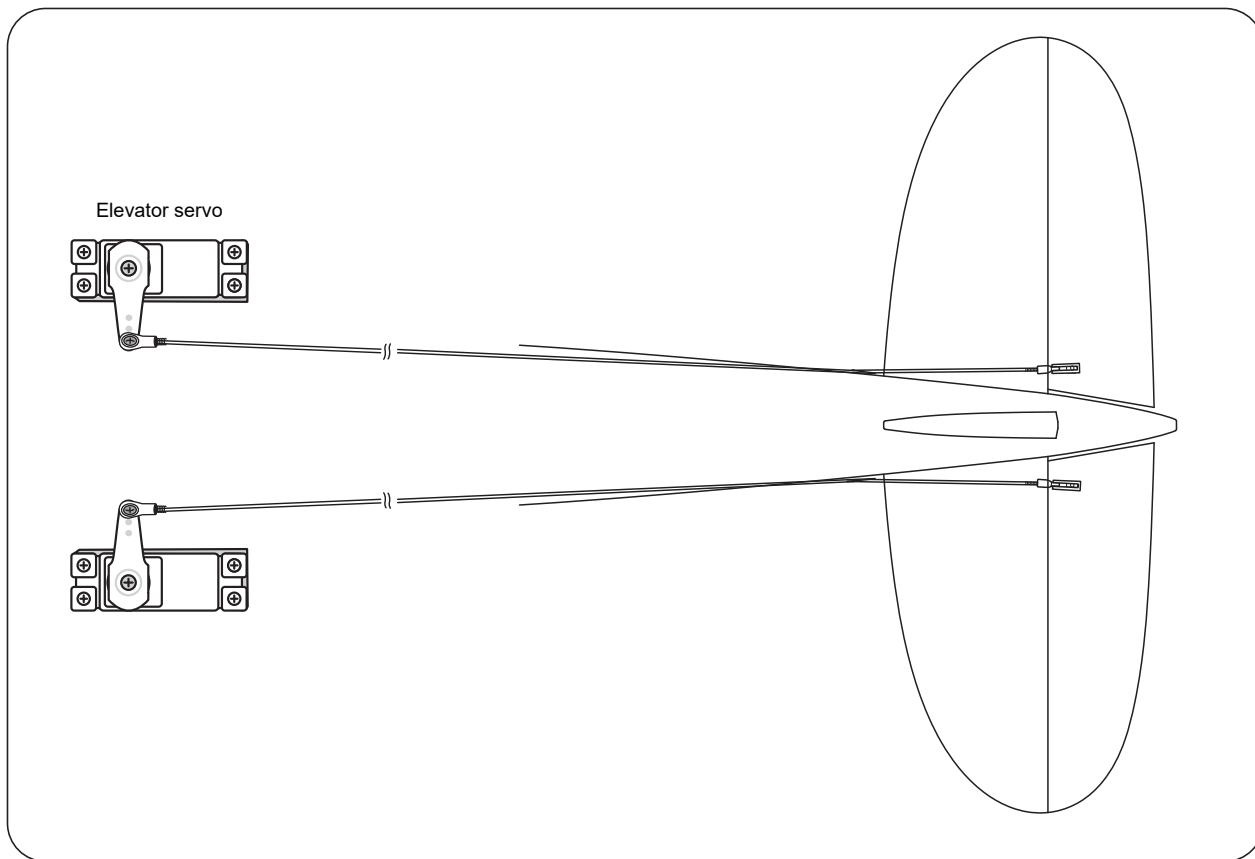
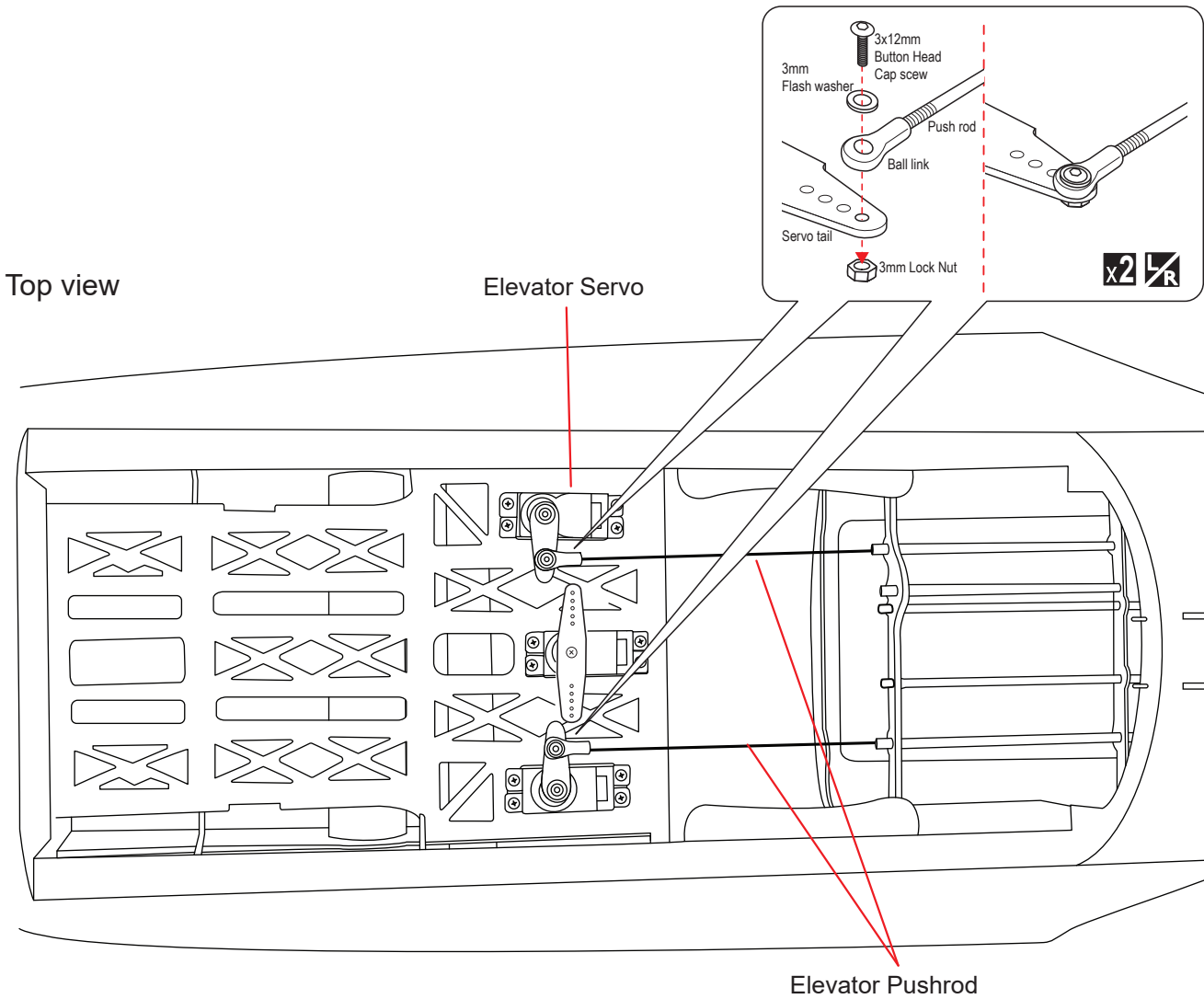



Cut off shaded portion carefully.

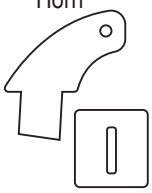

**x2** The number of times the same way Assembly (in this case twice).

**L/R** Assemble left and right sides the same way.

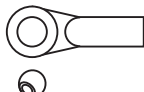
**INSTALLING THE RUDDER**

 --- 1	 --- 3	 - 1	 --- 2
 --- 2	 ---- 2	 --- 2	

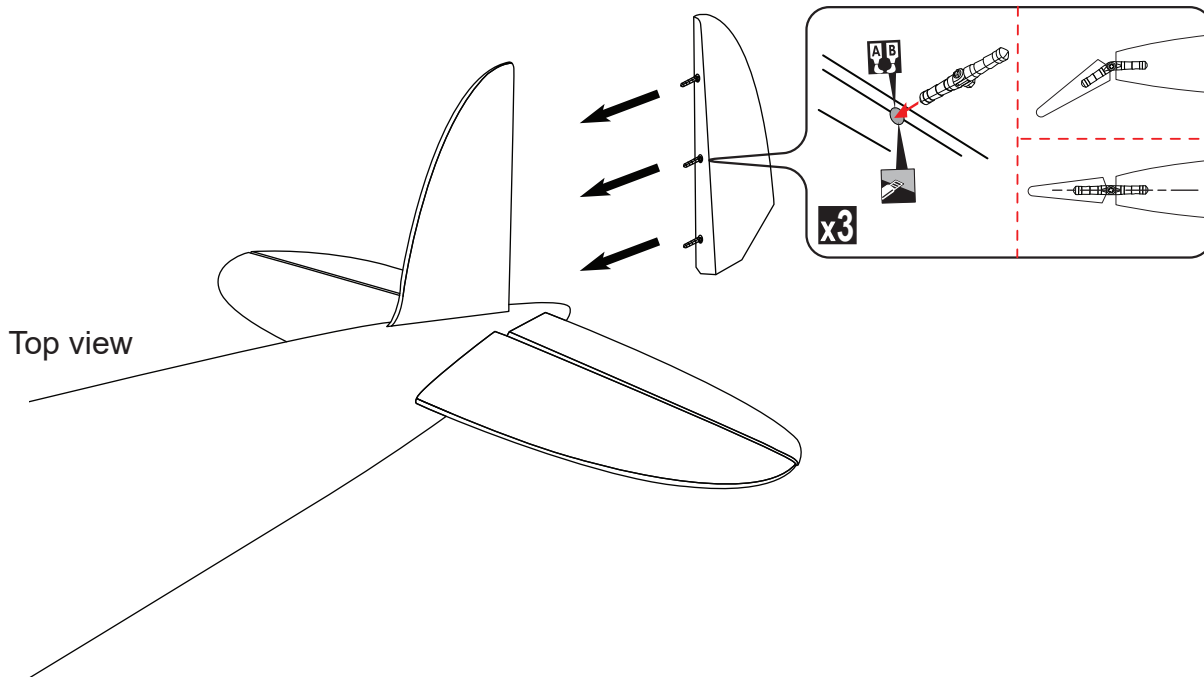

Top view

 Take off the main wing after put a rudder.

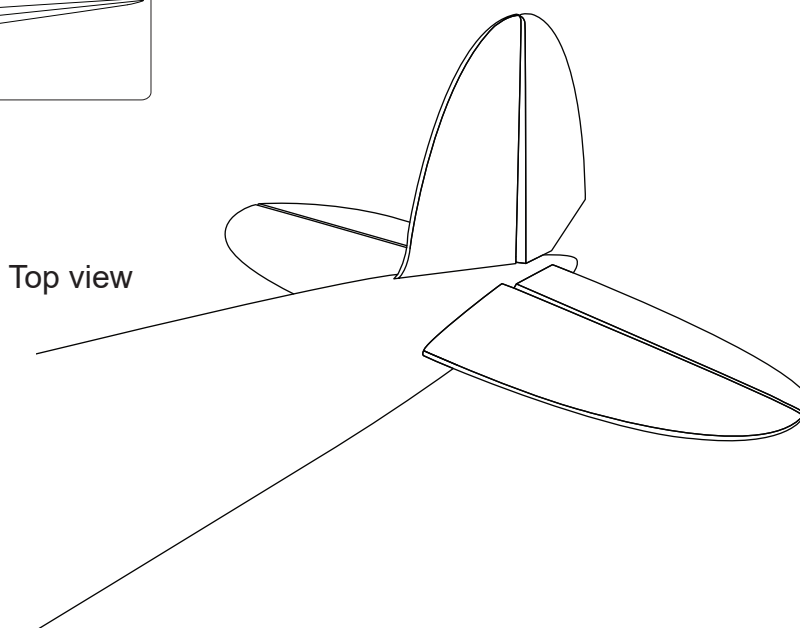
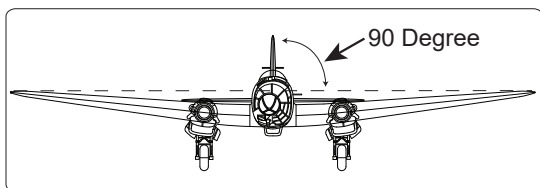

Top view



Cut off shaded portion carefully.



Apply epoxy glue.



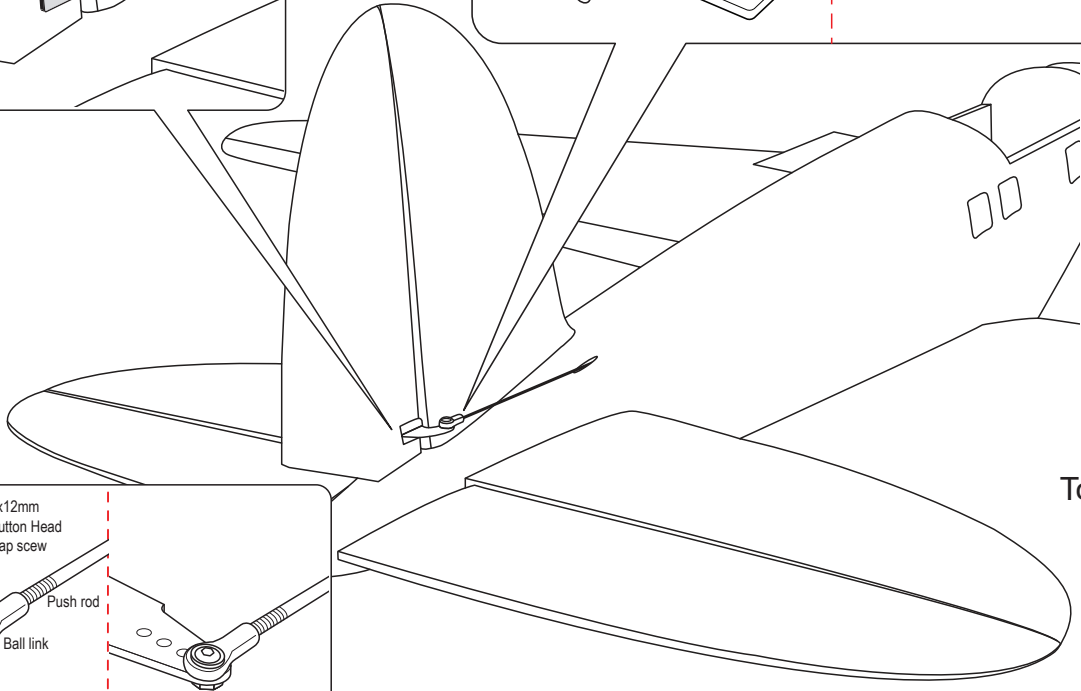
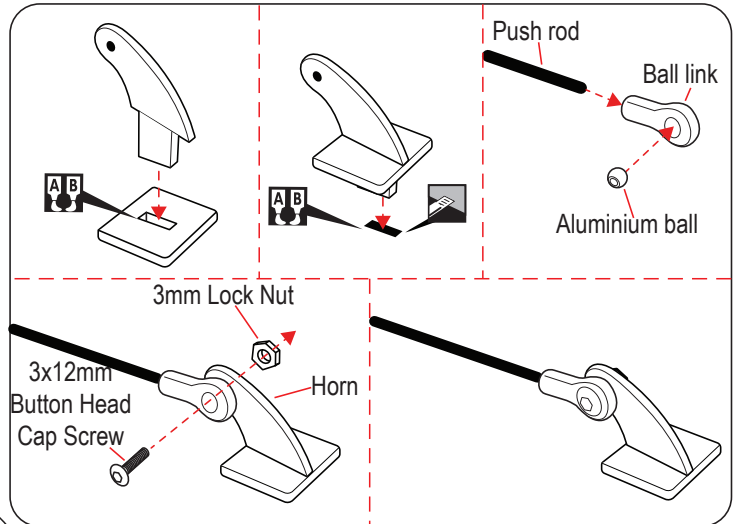
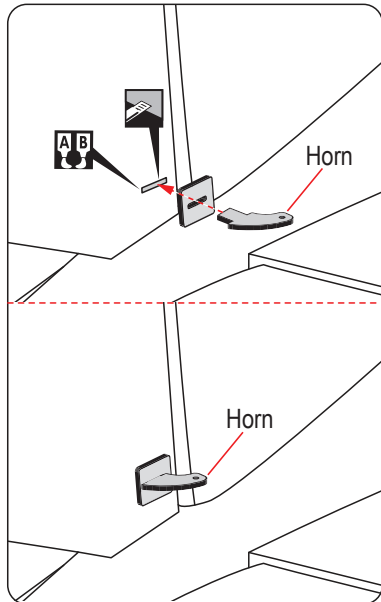

Top view

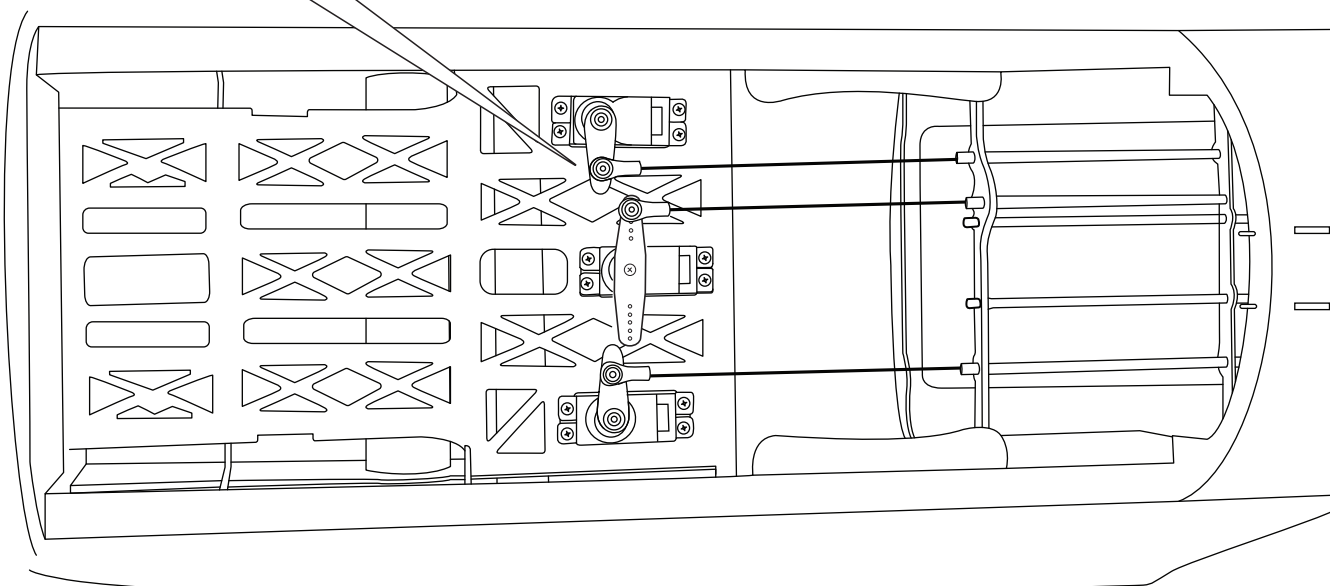
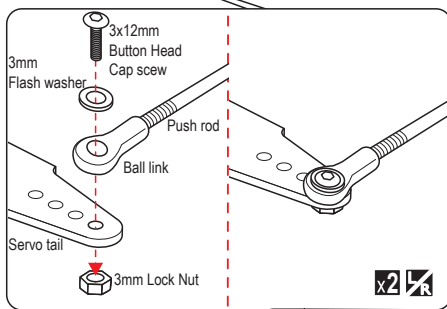

Apply epoxy glue.



Cut off shaded portion carefully

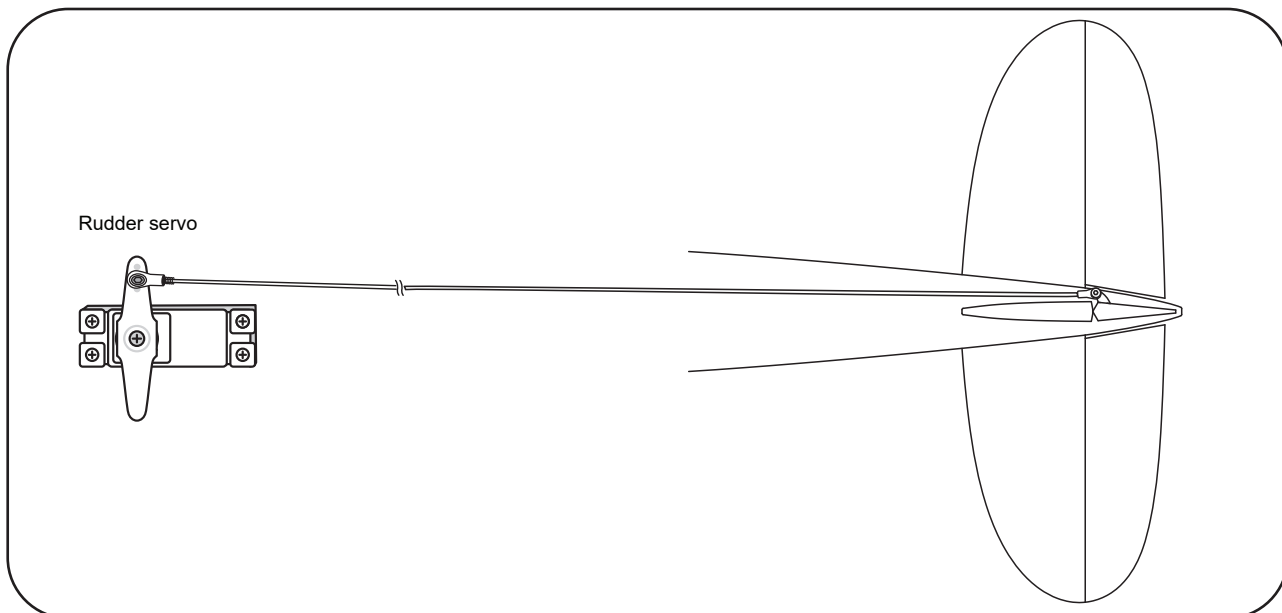

## INSTALLING THE TAIL GEAR

1200mm Cable rod ----- 2	Locknut ----- 4	3mm Hex Nut ----- 2	
3x30mm Cablink ----- 2	3x15mm Socket Head Cap Screw ----- 4	3mm Spring Washer ----- 4	
M3 Metal Clevis ----- 2	3mm Flat Washer ----- 4		

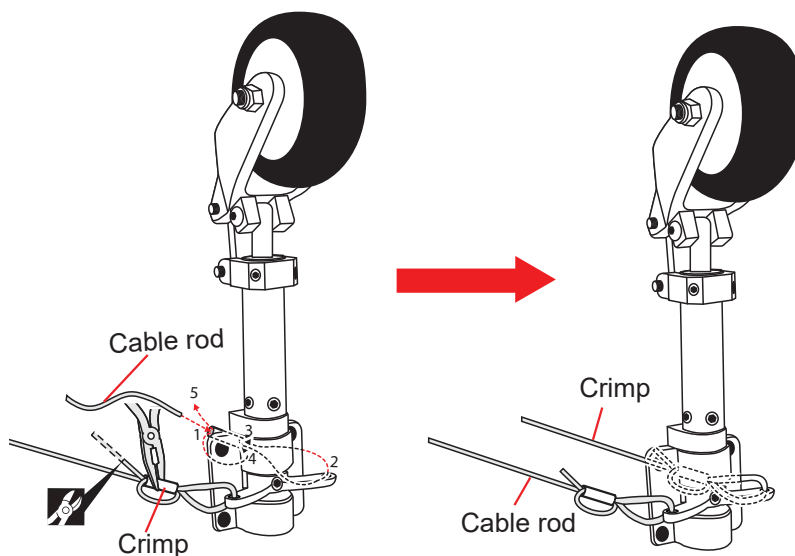

**x2** The number of times the same way Assembly (in this case twice).

**L/R** Assemble left and right sides the same way.

Bottom view

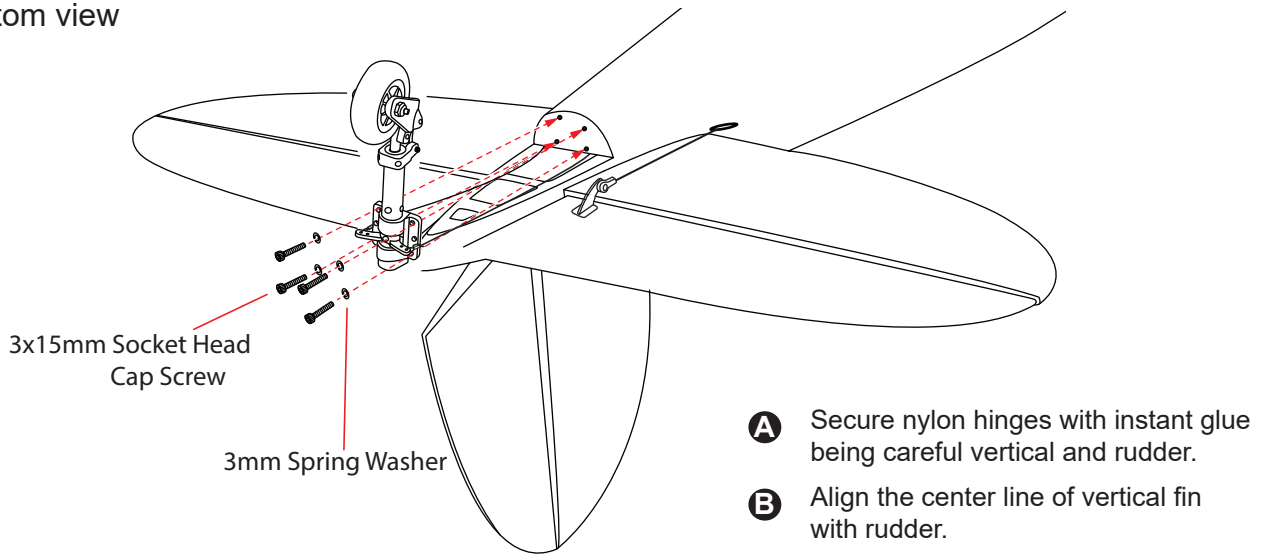

Bottom view

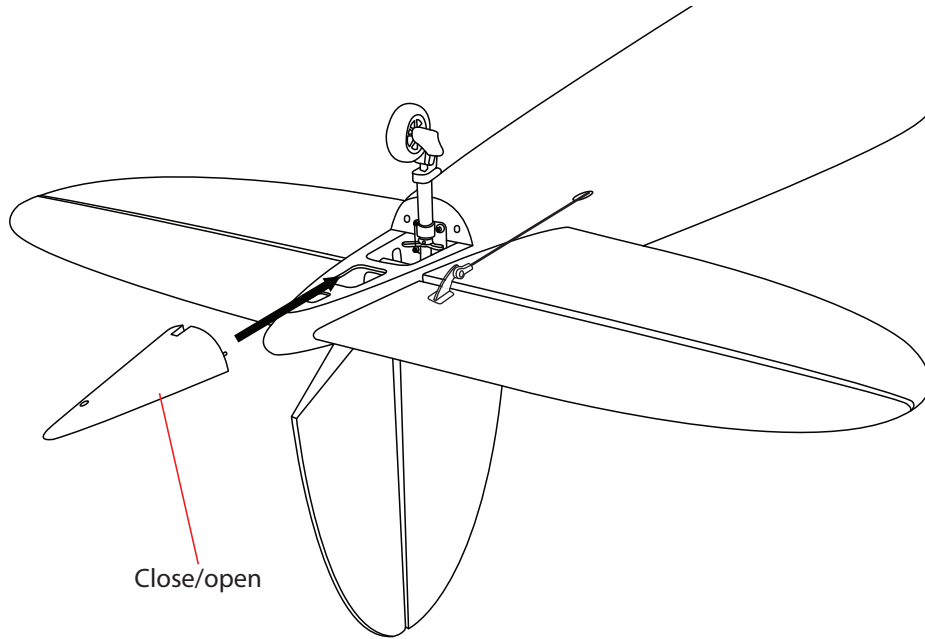

Bottom view

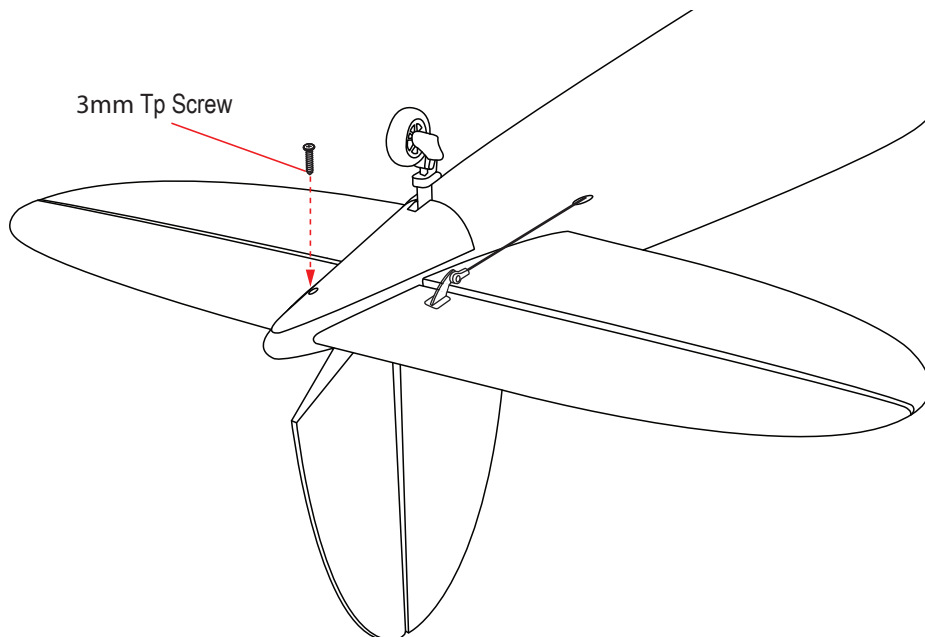

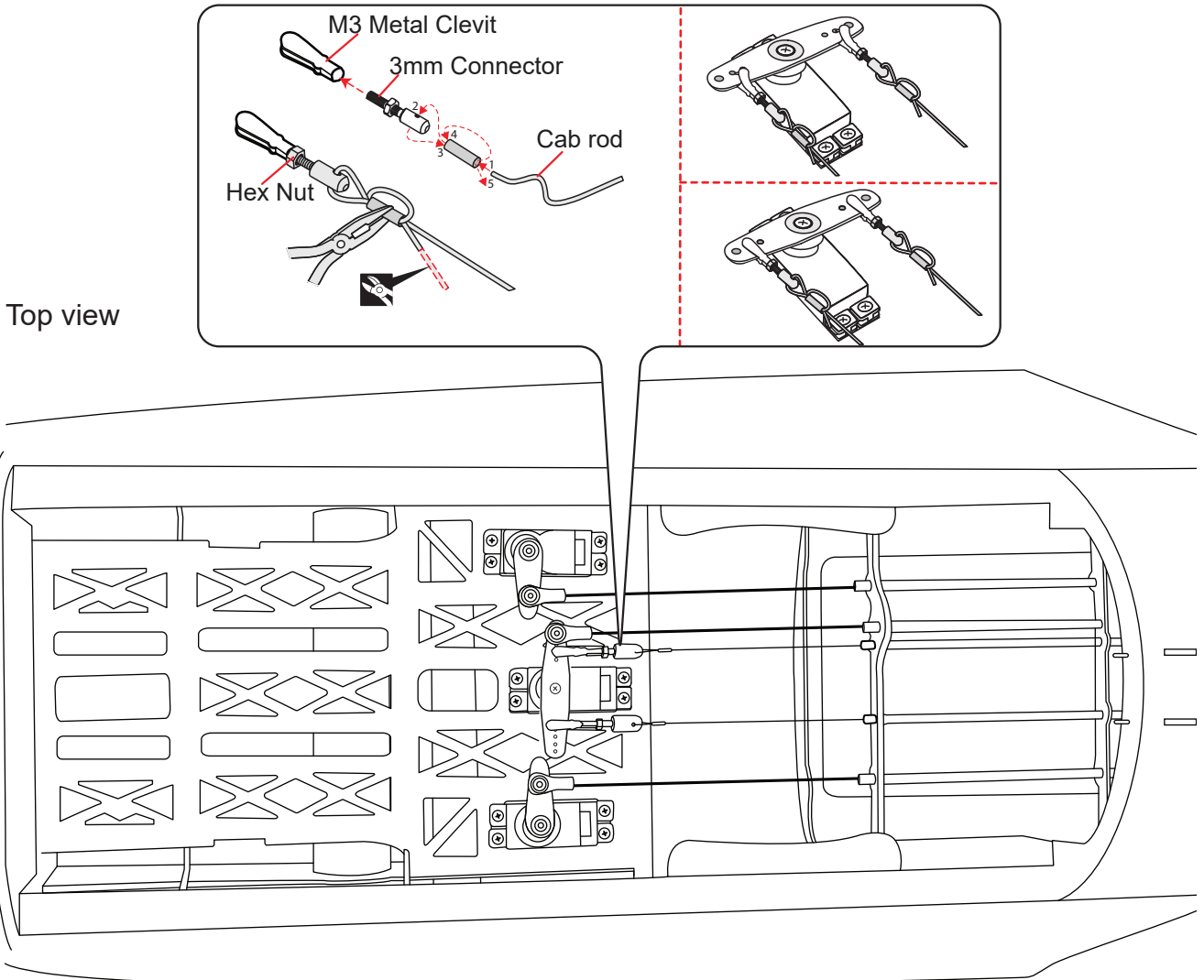
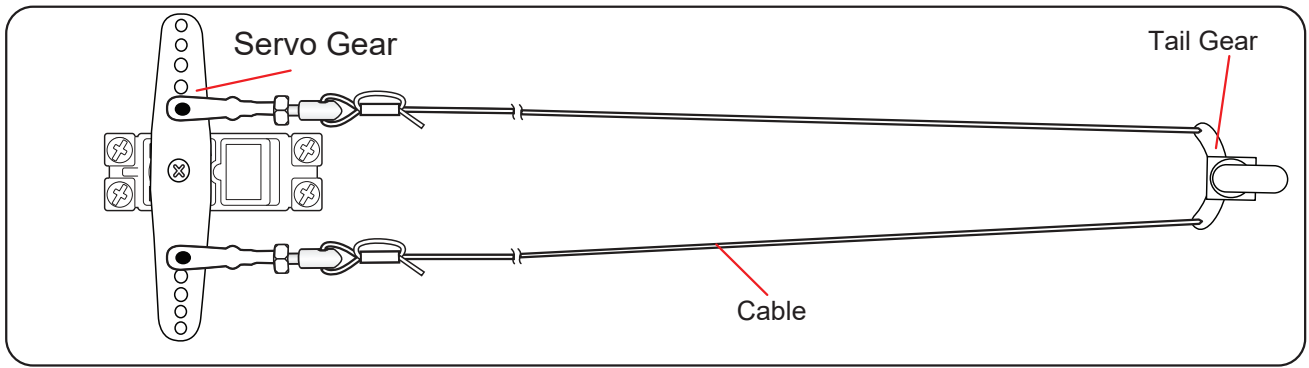

**SECURE THE WING TO THE FUSELAGE**

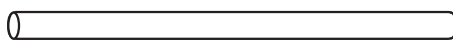
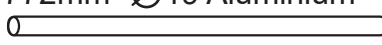
995mm Ø32 Aluminium	
	----- 1
772mm Ø19 Aluminium	
	----- 1

- Attack the wings to the joiner tube and secure the wing panels to the fuse lage.
- Main wing must be inserted and attached completely before fixing with crew.

Top view

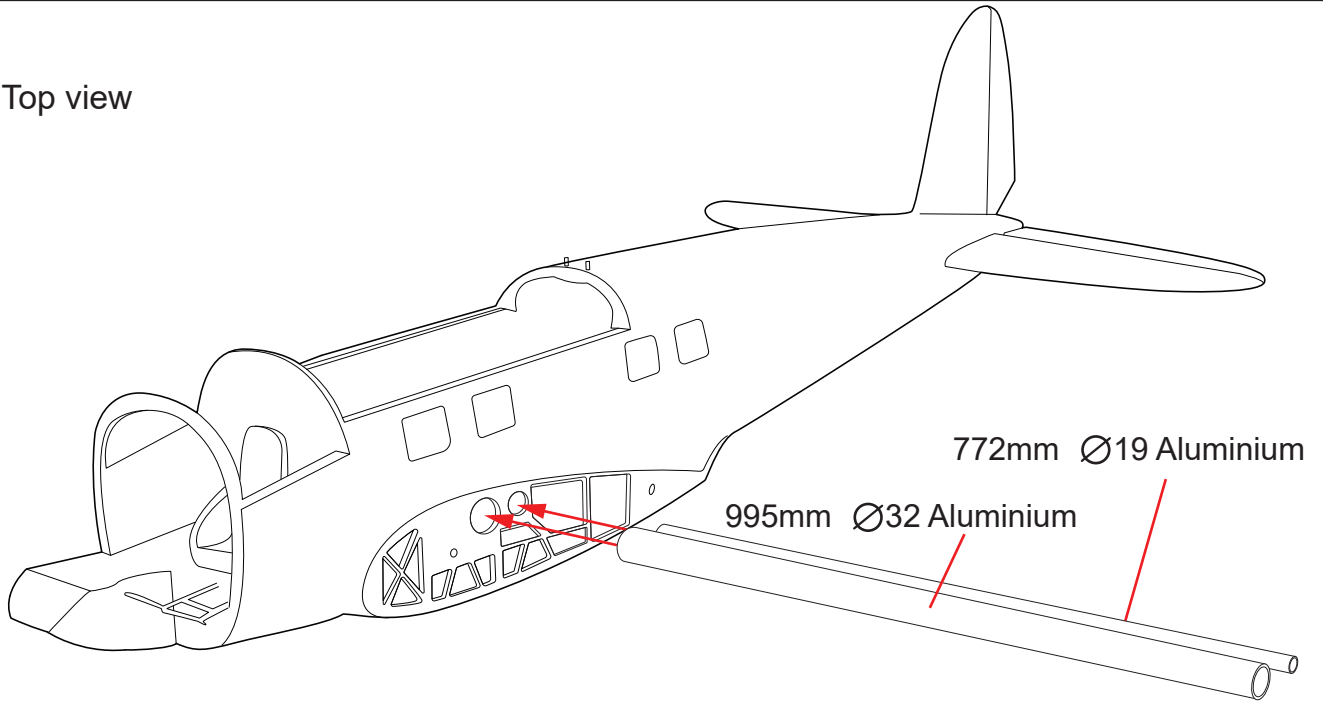

Top view

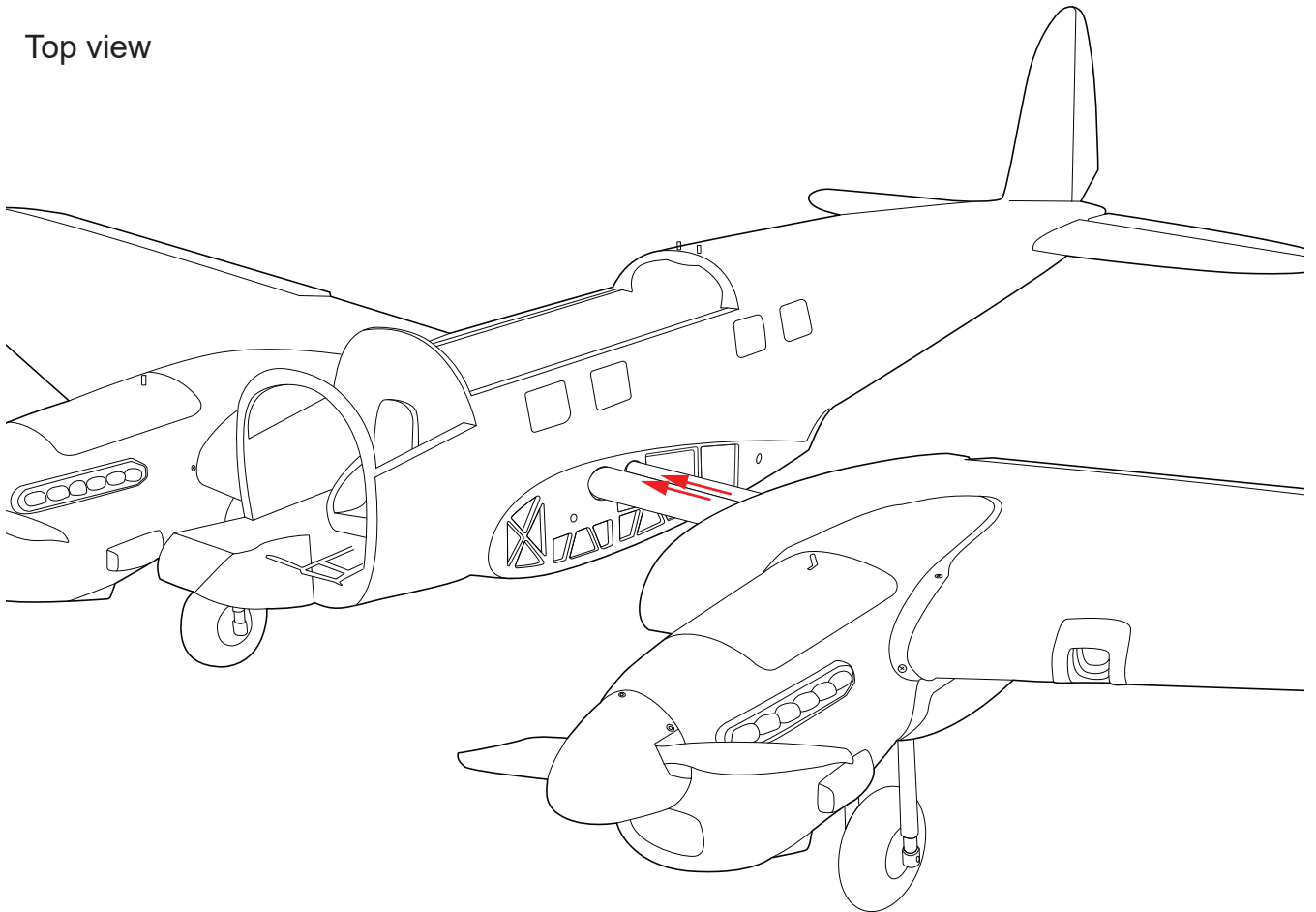

Top view

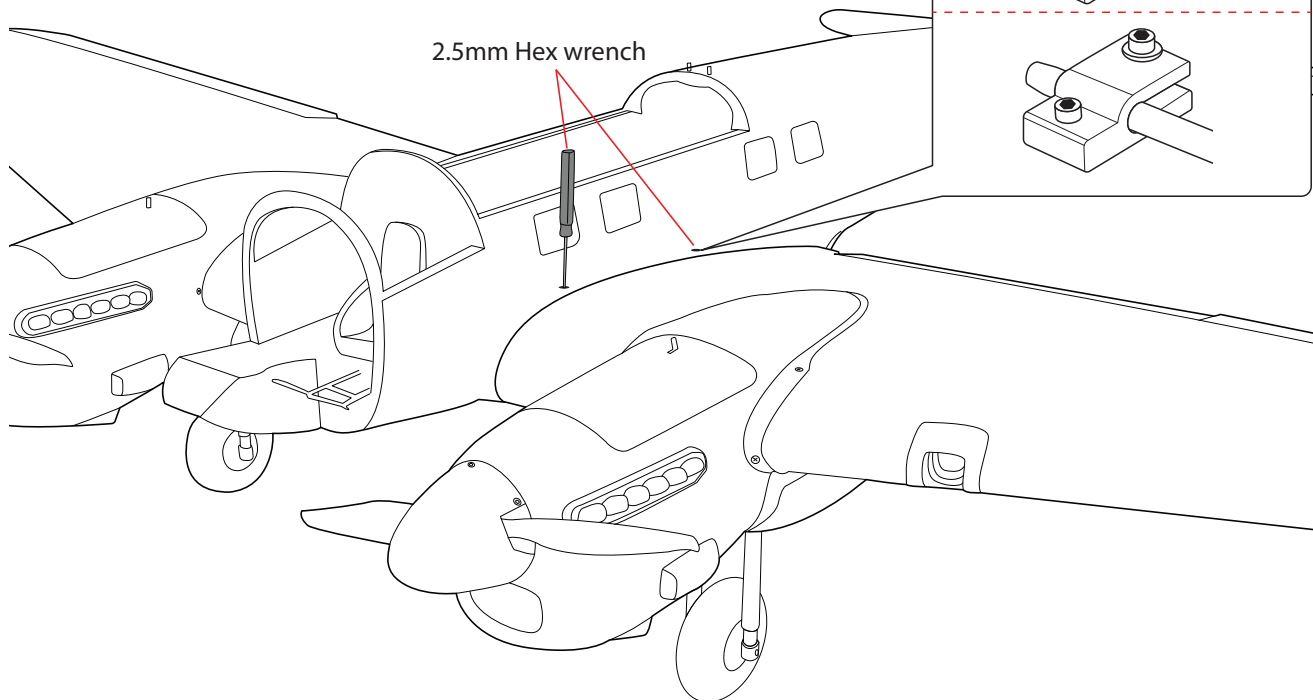

### INSTALLING THE RECEIVER AND BATTERY

1. Plug the servo leads and the switch lead into the receiver. You may want to plug an aileron extension into the receiver to make plugging in the aileron servo lead easier when you are installing the wing. Plug the battery pack lead into the switch.
2. Wrap the receiver and battery pack in the protective foam to protect them from vibration. Use a rubber band or masking tape to hold the foam in place.

**!** Do not permanently secure the receiver and battery until after balancing the model.

### INSTALLING THE SWITCH

1. The switch should be mounted on the fuselage side, opposite the muffler, close enough to the receiver so the lead will reach. Use the face plate of the switch cut out and locate the mounting holes.
2. Cut out the switch hole using a modeling knife. Use a 2mm drill bit and drill out the two mounting holes through the fuselage side.
3. Secure the switch in place using the two machine screws provided with the radio system.

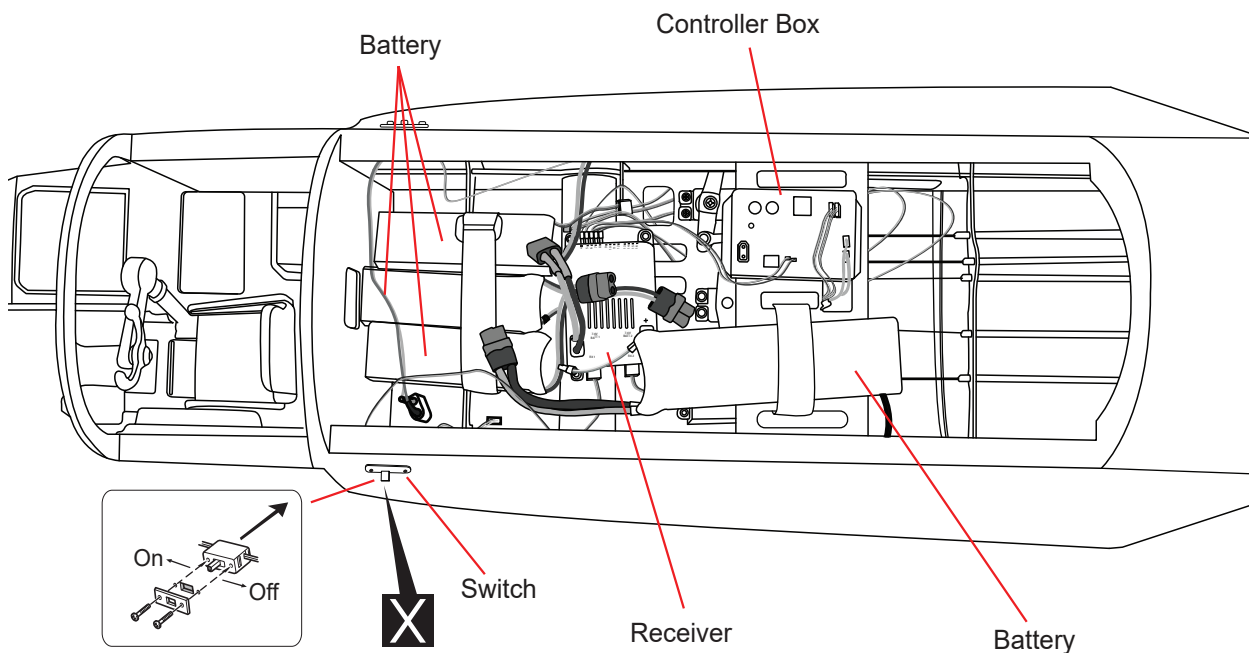

**INSTALLING CANOPY FUSELAGE**

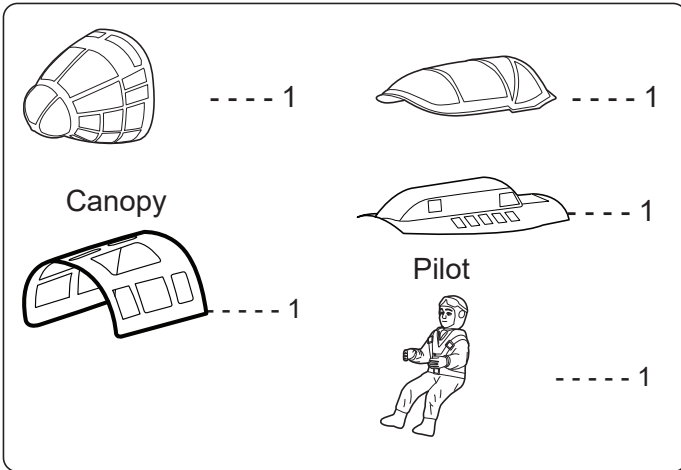

Position the canopy so the rear frame on the canopy is aligned with the rear edge of the cockpit opening. Use canopy glue to secure the canopy to the canopy hatch. Use low-tack tape to hold the canopy in position until the glue fully cures. Wrap the tape completely around the canopy hatch.

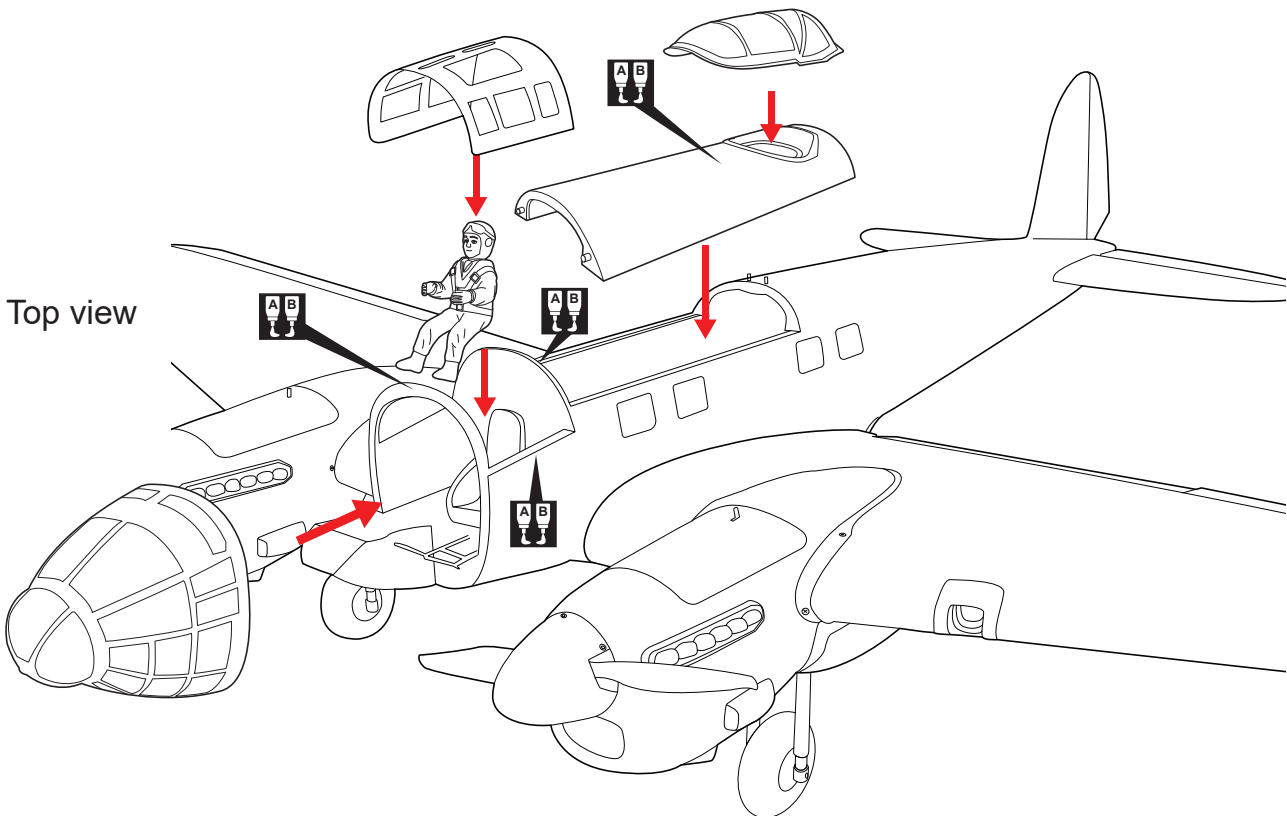

Top view

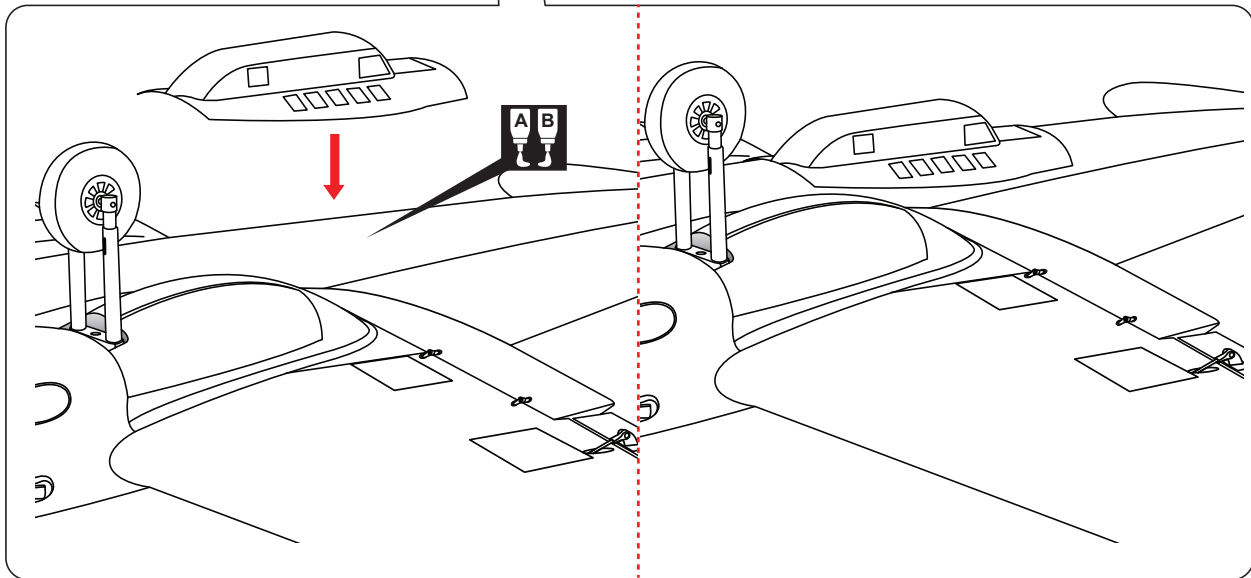
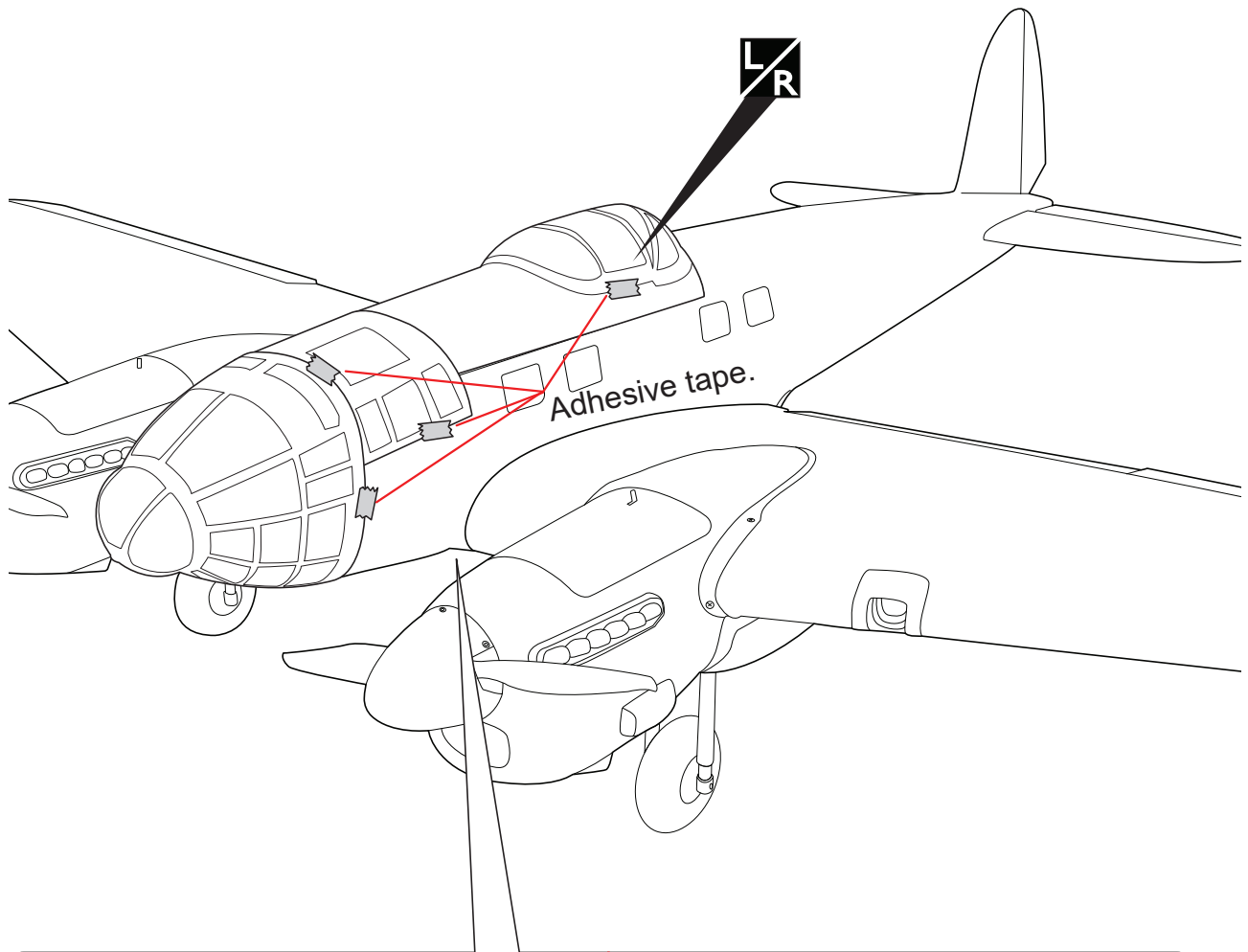



**INSTALLING PLASTIC FUSELAGE**

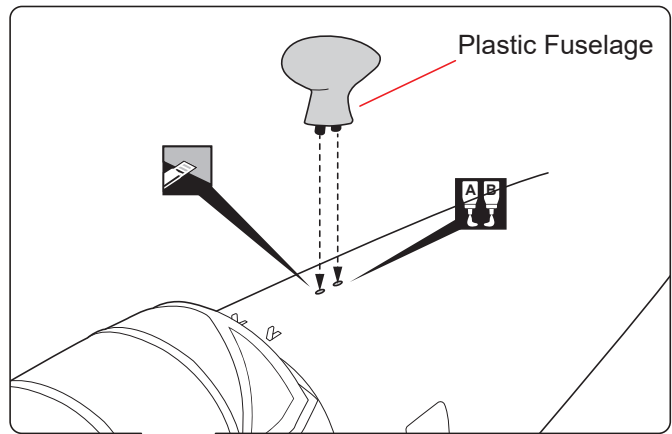
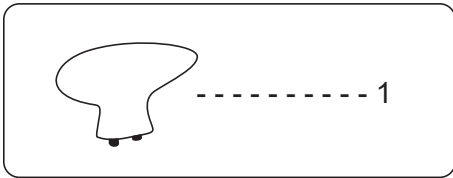

Top view

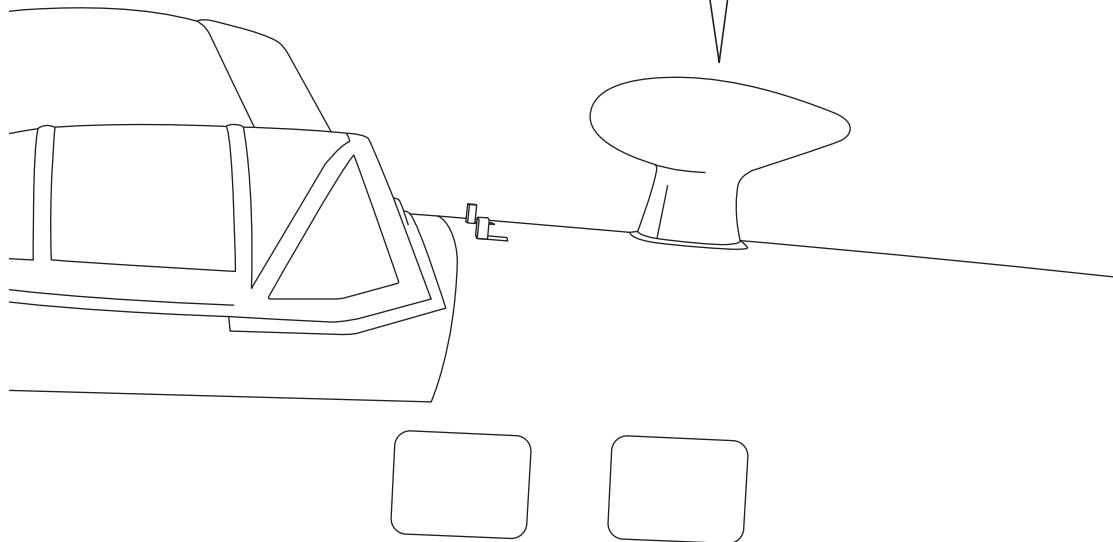

**INSTALLING THE ENGINE MOUNT**

Using plate of plywood (supplied with the kit) mark the holes onto the fire wall for installing the engine mount for ENGINE-20CC

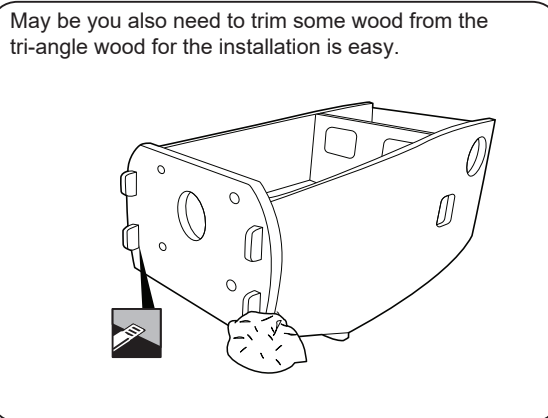
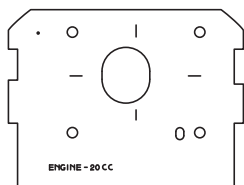

# ENGINE-20CC

Plate of plywood

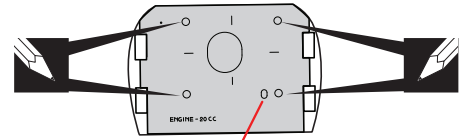
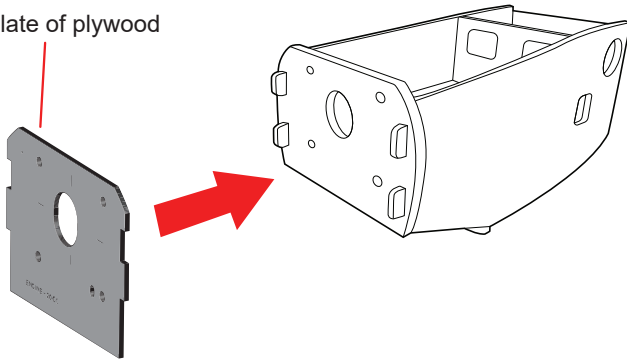

Throttle hole  
Φ 6mm

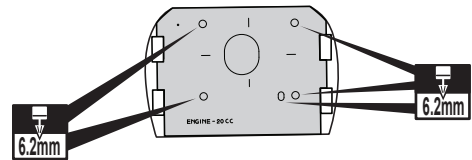

## INSTALLING THE ENGINE

4x30mm Socket Head Cap Screw



--- 16



----- 8

4mm Lock Nut



--- 8

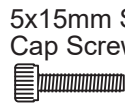

5x15mm Socket Head Cap Screw

--- 8

4mm Flat Washer



--- 16



5x16mm Flat Washer

--- 8

4mm Spring Washer



--- 16



Connector

--- 2

500mm Pushrod wire



--- 2

<Left>



----- 2

<Right>



----- 2

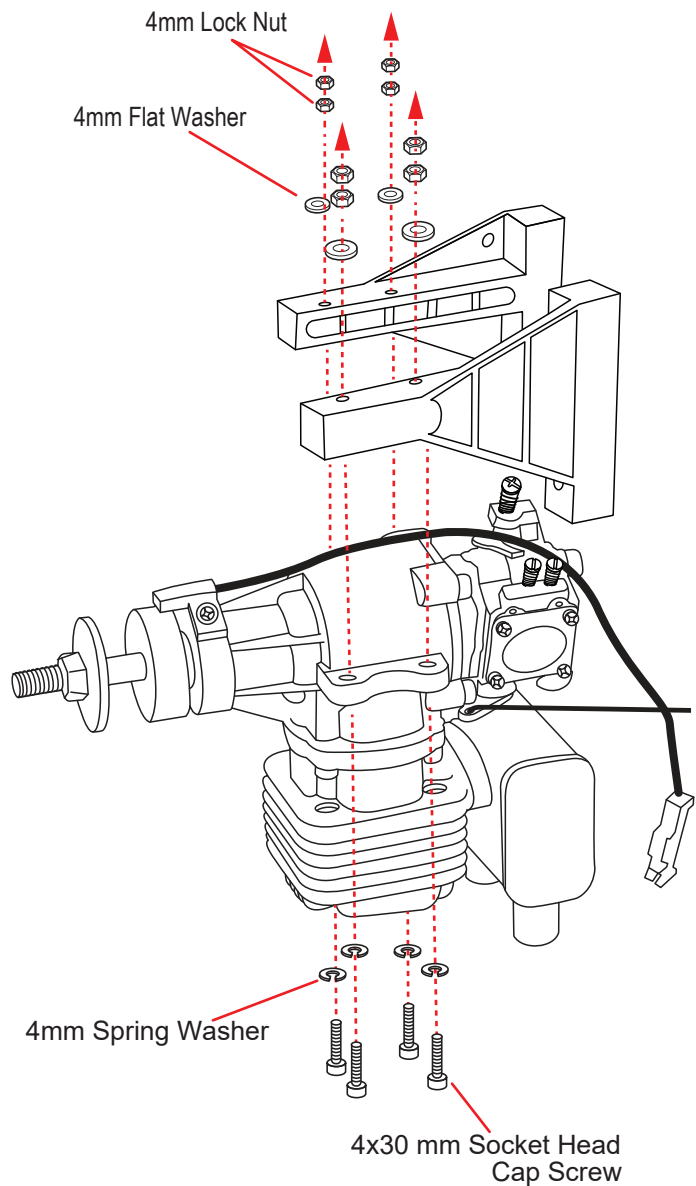

4mm Lock Nut

4mm Flat Washer

4mm Spring Washer

4x30 mm Socket Head Cap Screw



Drill holes using the stated (in this case 1.5mm ø).



Cut off shaded portion carefully.



Use a pencil to mark

Top view

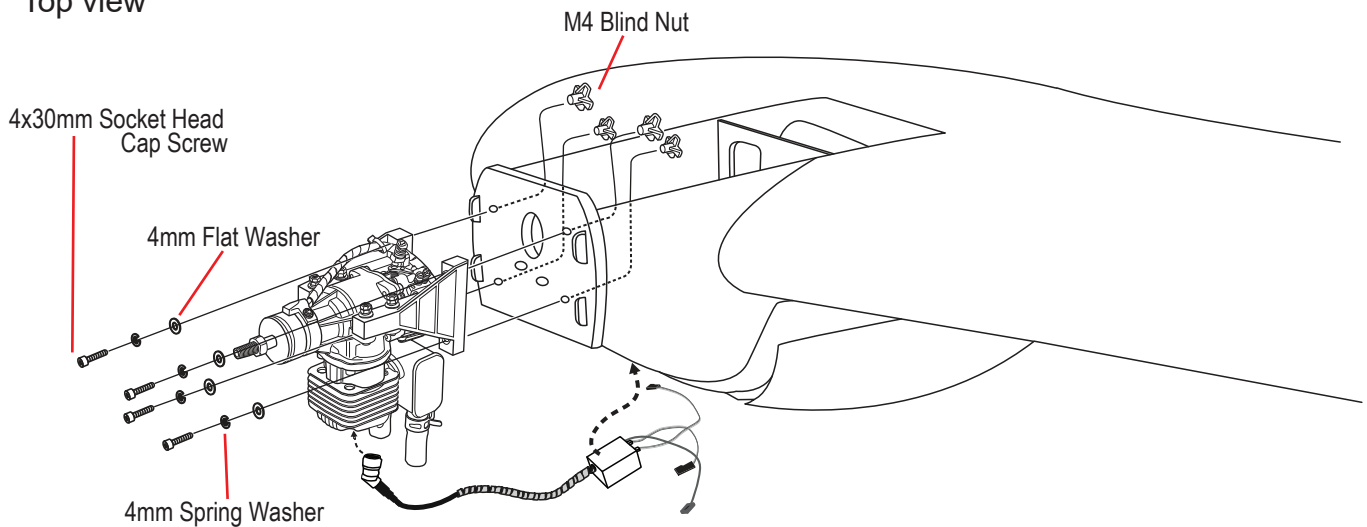

Top view

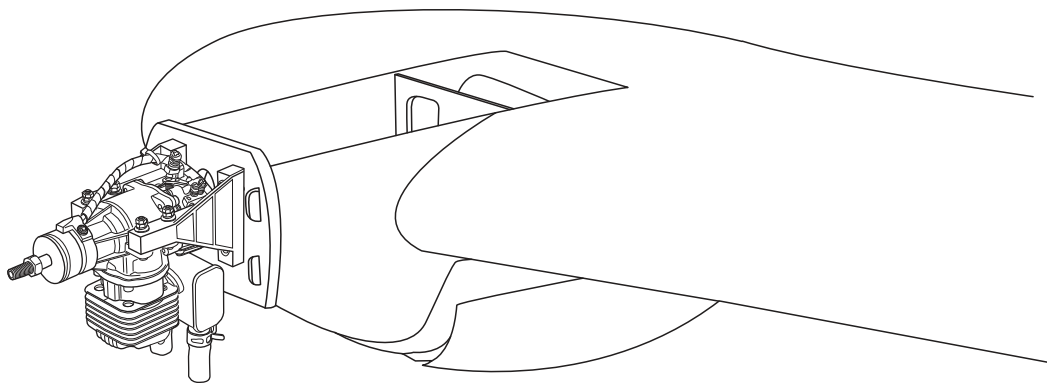

## INSTALLATION THE FUEL TANK

1) Using a modeling knife, cut one length of silicon fuel line (the length of silicon fuel line is calculated by how the weighted clunk should rest about 8mm away from the rear of the tank and move freely inside the tank). Connect one end of the line to the weighted clunk and the other end to the nylon pickup tube in the stopper.

2) Carefully bend the second nylon tube up at a 45 degree angle (using a cigarette lighter). This tube will be the vent tube to the muffler.

3) Carefully bend the third nylon tube down at a 45 degree angle (using a cigarette lighter). This tube will be vent tube to the fueling valve.



When the stopper assembly is installed in the tank, the top of the vent tube should rest just below the top surface of the tank. It should not touch the top of the tank.

4) Test fit the stopper assembly into the tank. It may be necessary to remove some of the flashing around the tank opening using a modeling knife. If flashing is present, make sure none of it falls into the tank.

6) When satisfied with the alignment of the stopper assembly tighten the 3mm x 20mm machine screw until the rubber stopper expands and seals the tank opening. Do not over tighten the assembly as this could cause the tank to split.

7) Using a modeling knife, cut 3 lengths of fuel line. Connect 2 lines to the 2 vent tubes and 1 line to the fuel pickup tube in the stopper.







8) Feed three lines through the fuel tank compartment and through the pre-drilled hole in the firewall. Pull the lines out from behind the engine, while guiding the fuel tank into place. Push the fuel tank as far forward as possible, the front of the tank should just about touch the back of the firewall.

Blow through one of the lines to ensure the fuel lines have not become kinked inside the fuel tank compartment. Air should flow through easily.

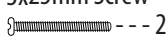

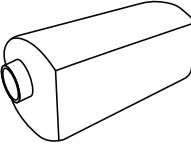
Do not secure the tank into place permanently until after balancing the airplane. You may need to remove the tank to mount the battery in the fuel tank compartment.

8) Secure the fuel tank.

 Clunks --- 2	 3x25mm Screw --- 2	 58mm Copper tube --- 8	 Fiber glass --- 2
 Rubber --- 2	 Aluminium --- 2	 Metal --- 2	

INSTALLING THE STOPPER

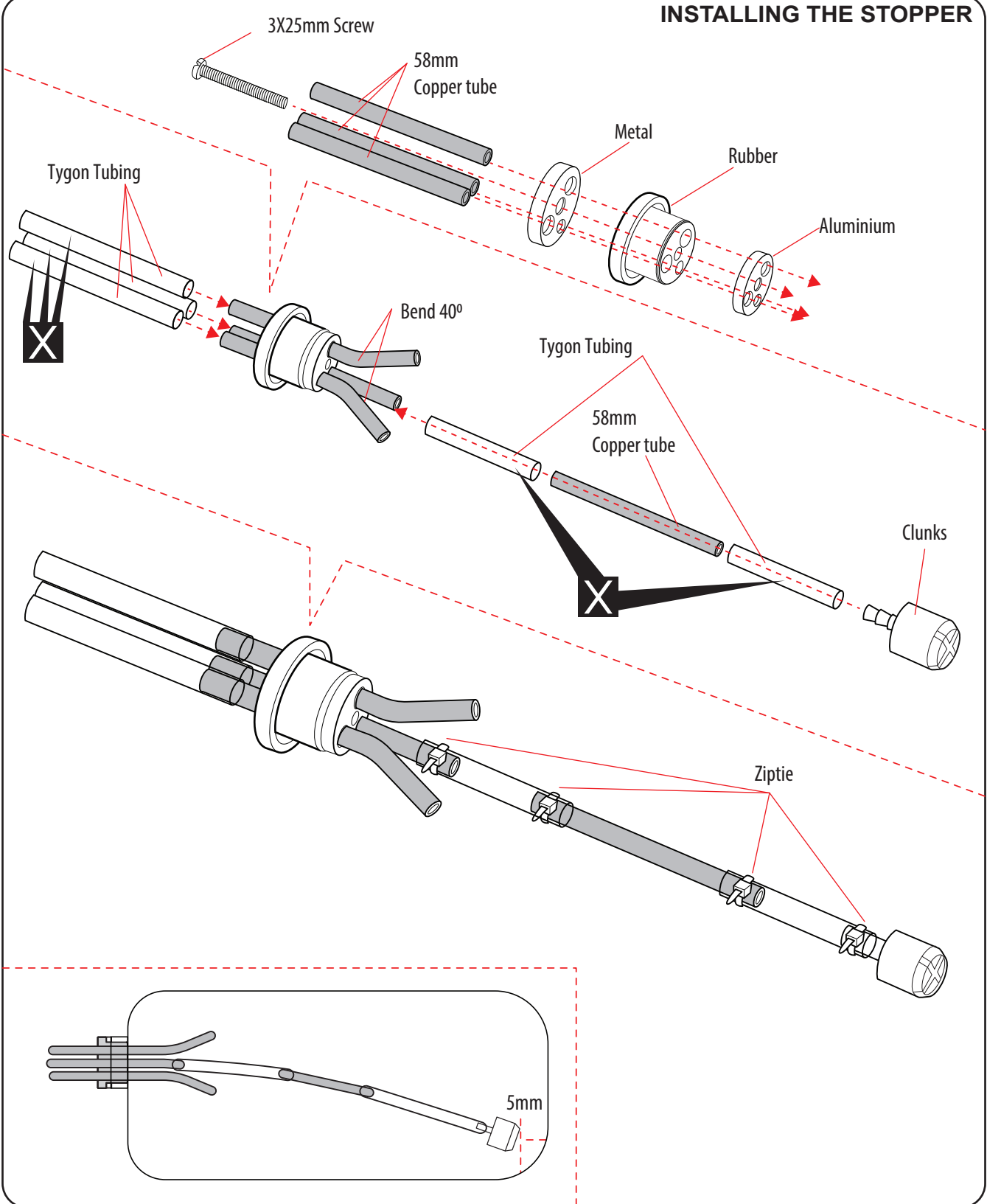

Bottom view

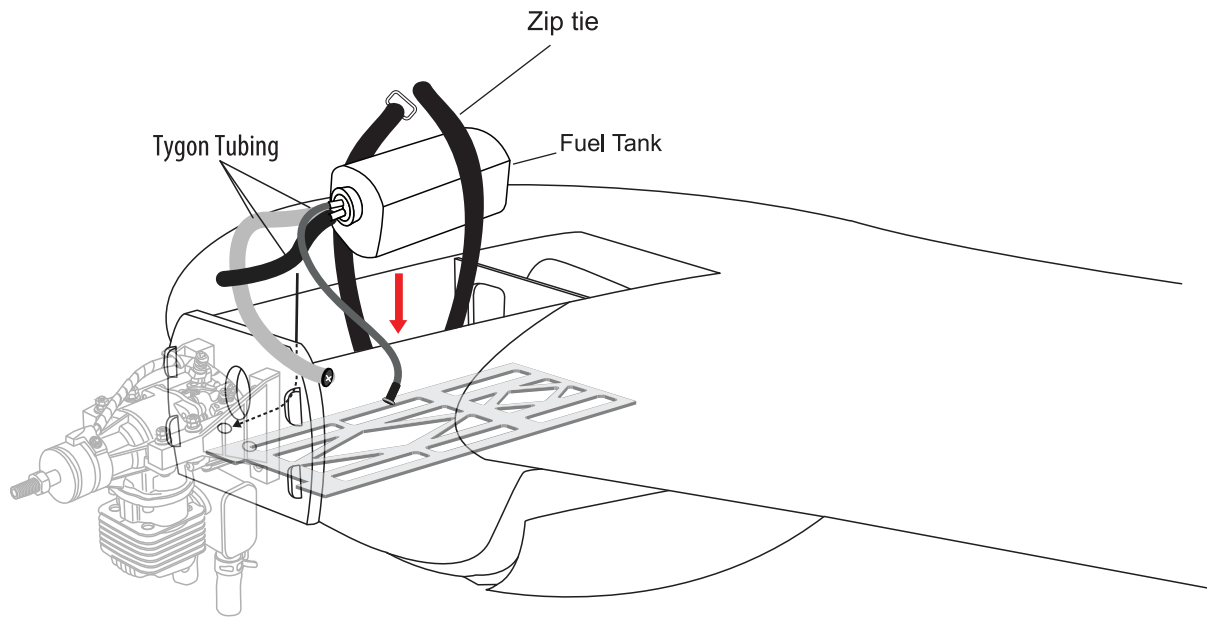

Bottom view

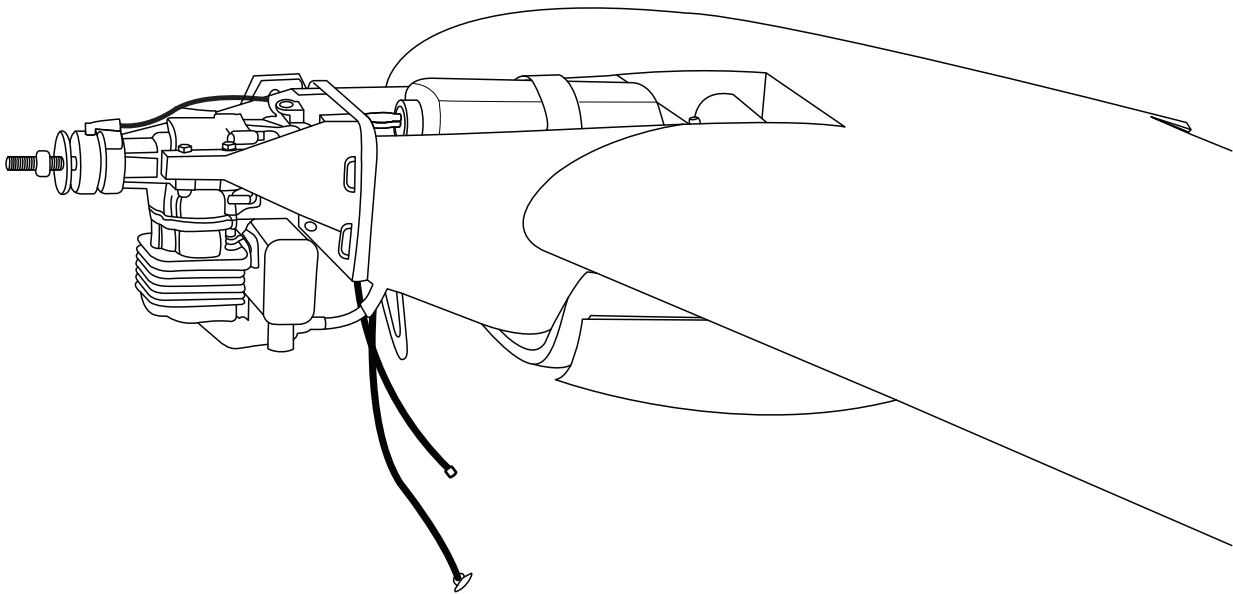

### INSTALLING THE THROTTLE

1. Install one adjustable metal connector through the third hole out from the center of one servo arm, enlarge the hole in the servo arm using a 2mm drill bit to accommodate the servo connector. Remove the excess material from the arm.

**!** After installing the adjustable metal connector apply a small drop of thin C/A to the bottom nut. This will prevent the connector from loosening during flight.

2. Plug the throttle servo into the receiver and turn on the radio system. Check to ensure that the throttle servo output shaft is moving in the correct direction. When the throttle stick is moved forward from idle to full throttle, the throttle barrel should also open and close using this motion. If not, reverse the direction of the servo, using the transmitter.

3. Slide the adjustable metal connector / servo arm assembly over the plain end of the pushrod wire. Position the throttle stick and the throttle trim at their lowest positions.

4. Manually push the carburetor barrel fully closed. Angle the arm back about 45 degree from center and attach the servo arm onto the servo. With the carburetor barrel fully closed, tighten the set screw in the adjustable metal connector.

5. Remove the excess throttle pushrod wire using wire cutters and install the servo arm retaining screw.

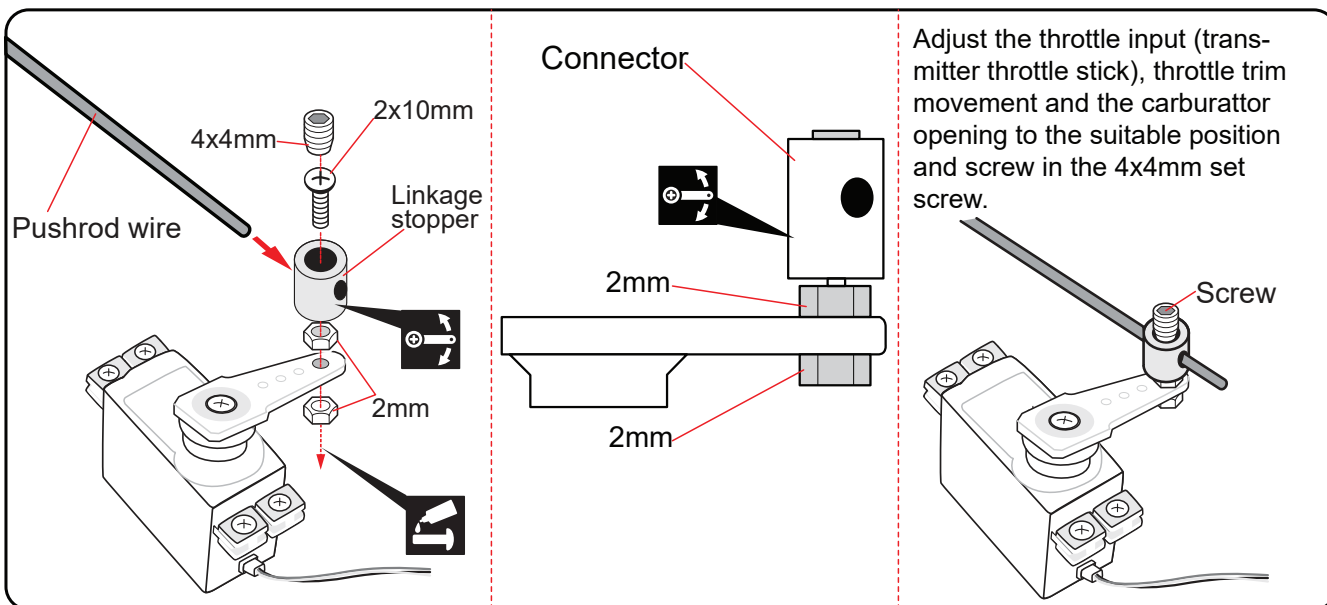
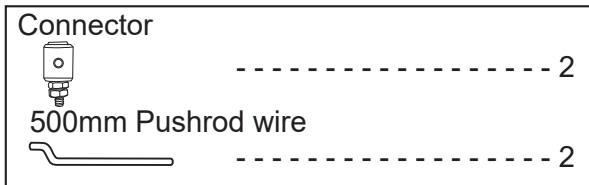

Top view

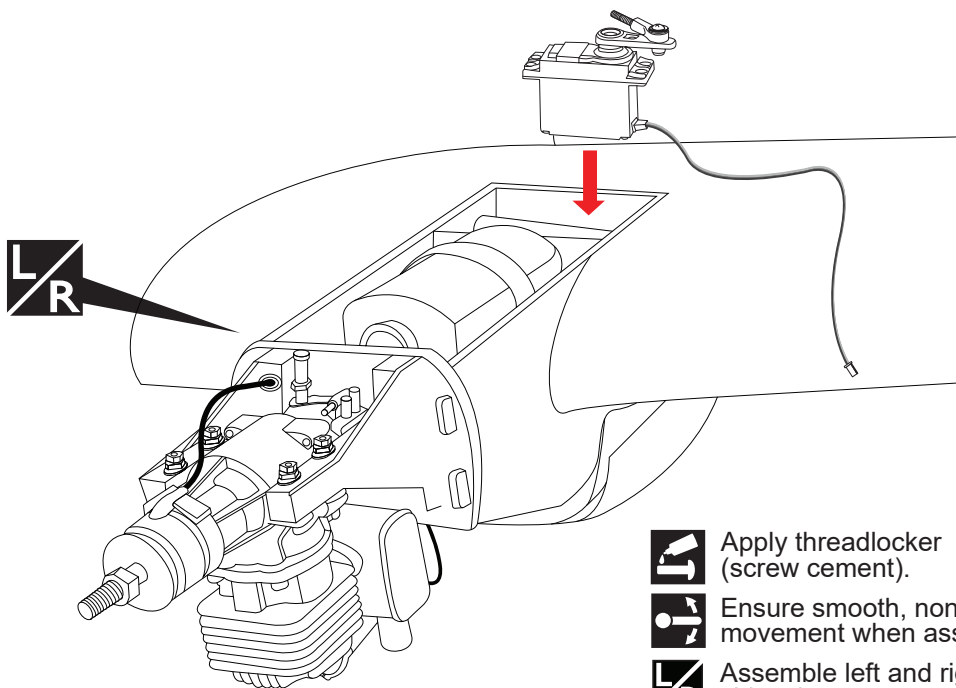

- Apply threadlocker (screw cement).
- Ensure smooth, non-binding movement when assembling.
- Assemble left and right sides the same way.

**MOUNTING THE COWL**

1. Remove the muffler and needle valve assembly from the engine. Slide the fiberglass cowl over the engine.
  2. Measure and mark the locations to be cut out for engine head clearance, needle valve, muffler. Remove the cowl and make these cutouts using a rotary tool with a cutting disc and a rotary sanding drum attachment.
  3. Slide the cowl back into place. Align the front of the cowl with the crankshaft of the engine. The front of the cowl should be positioned so the crankshaft is in the middle of the precut opening. Hold the cowl firmly in place using several pieces of masking tape.
  4. While holding the cowl firmly in position, drill four 1,6mm pilot holes through both the cowl and the side edges of the firewall.
  5. Using a 3mm drill bit, enlarge the four holes in the cowling.
-  *Enlarging the holes through the cowl will prevent the fiberglass from splitting when the mounting screws are installed.*
6. Slide the cowl back over the engine and secure it in place using four screws.
  7. Install the muffler. Connect the fuel and pressure lines to the carburator, muffler and fuel filler valve. Tighten the screws completely.

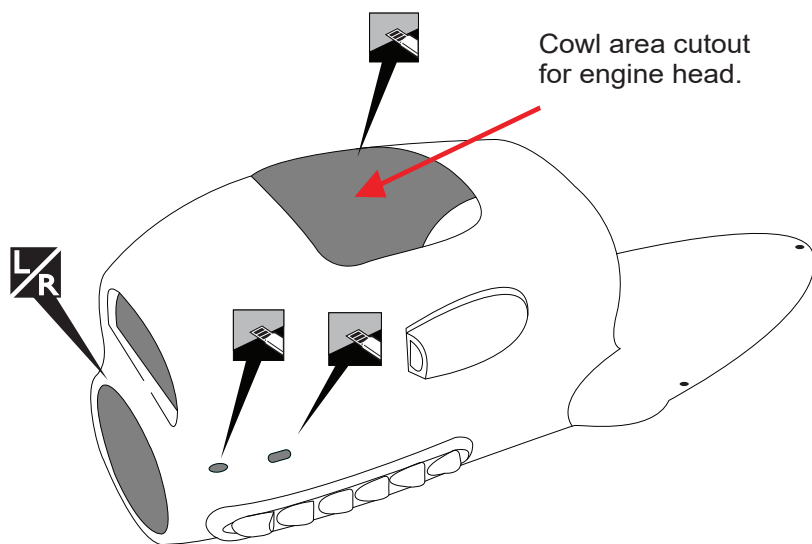

Top view

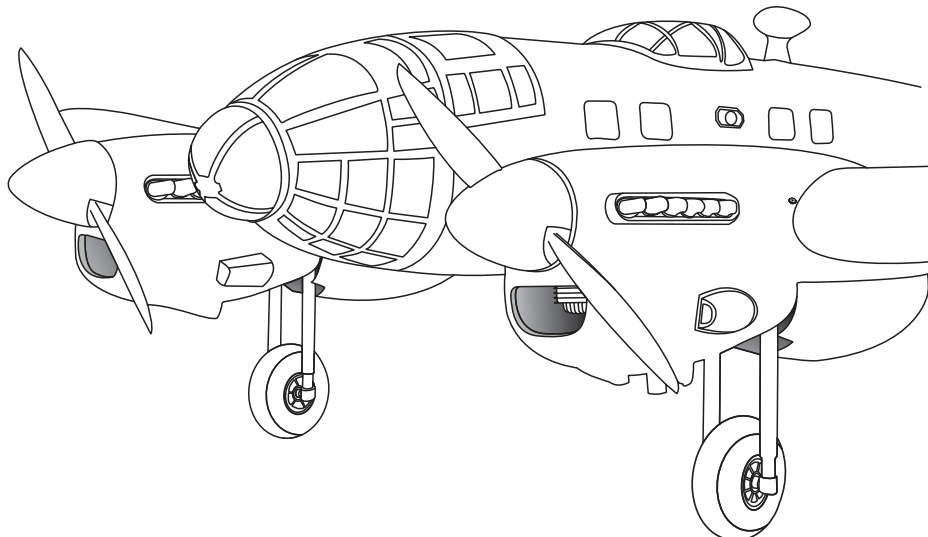

 Cut off shaded portion carefully

 Assemble left and right sides the same way.

**BALANCING**

1) It is critical that your airplane be balanced correctly. Improper balance will cause your plane to lose control and crash.

THE CENTER OF GRAVITY IS LOCATED 130MM BACK FROM THE LEADING EDGE OF THE WING. AT THE FUSELAGE. BALANCE A PLANE UPSIDE DOWN WITH THE FUEL TANK EMPTY.

2) Mount the wing to the fuselage. Using a couple of pieces of masking tape, place them on the top side of the wing 130mm back from the leading edge, at the fuselage sides.

3) Turn the airplane upside down. Place your fingers on the masking tape and carefully lift the plane.

4) If the nose of the plane falls, the plane is nose heavy. To correct this first move the battery pack further back in the fuselage. If this is not possible or does not correct it, stick small amounts of lead weight on the fuselage under the horizontal stabilizer. If the tail of the plane falls, the plane is tail heavy. To correct this, move the battery and receiver forward or if this is not possible, stick weight into the firewall. When balanced correctly, the airplane should sit level or slightly nose down when you lift it up with your fingers.

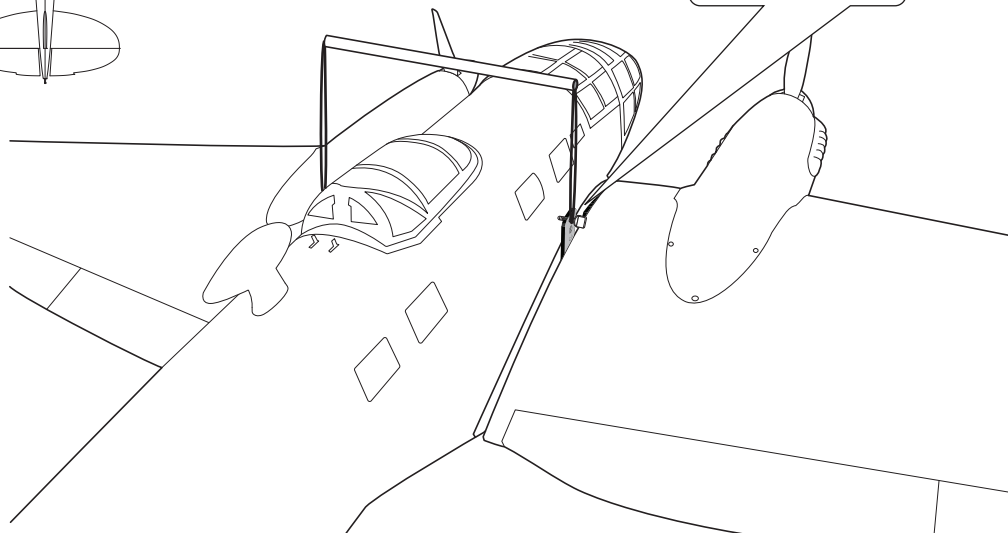
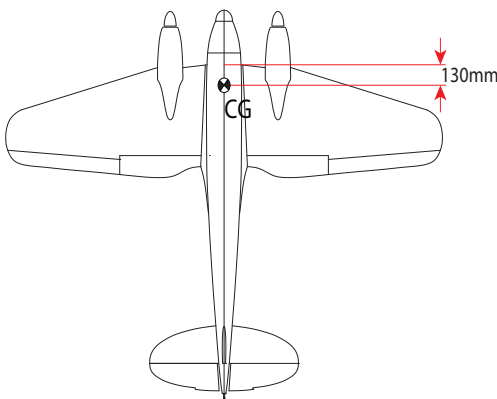

**LATERAL BALANCE**

 After you have balanced a plane on the C.G. You should laterally balance it. Doing this will help the airplane track straighter .

1) Turn the airplane upside down. Attach one loop of heavy string to the engine crankshaft and one to the tail wheel wire. With the wings level, carefully lift the airplane by the string. This may require two people to make it easier.

2) If one side of the wing fall, that side is heavier than the opposite. Add small amounts of lead weight to the bottom side of the lighter wing half's wing tip. Follow this procedure until the wing stays level when you lift the airplane.

- |                        |     |   |
|------------------------|-----|---|
| 6 x 25mm Plastic Screw | --- | 2 |
| Plate of plywood       | --- | 2 |
| Aluminium Ø12mm        | --- | 1 |
| 2000mm Wire            | --- | 1 |



- ▶ In order to obtain the CG specified, reposition the receiver and other equipment.
- ▶ If not obtain the CG specified, add a weight and adjust.

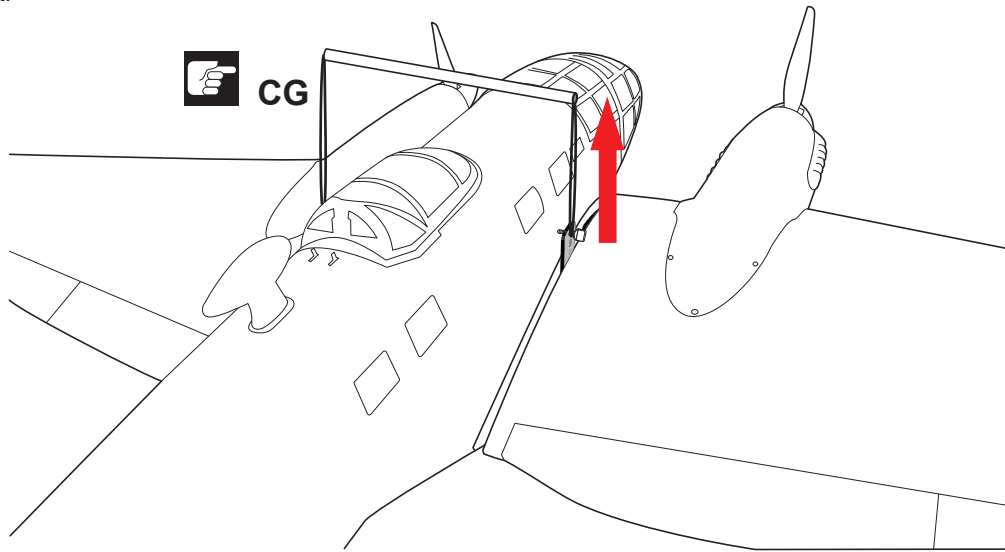

- ▶ Do not fly before confirming the correct location of the CG. If the CG is incorrect, you lose control of your airplane which leads to accidents.

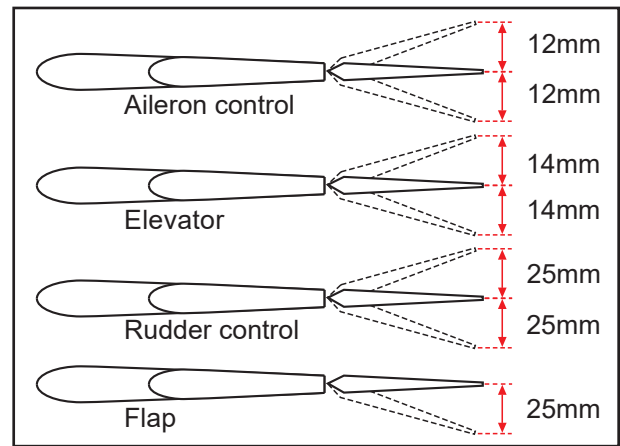

### PRE-FLIGHT CHECK

- 1) Completely charge your transmitter and receiver batteries before your first day of flying.
- 2) Check every bolt and every glue joint in your plane to ensure that everything is tight and well bonded.
- 3) Double check the balance of the airplane.
- 4) Check the control surface.
- 5) Check the receiver antenna. It should be fully extended and not coiled up inside the fuselage.
- 6) Properly balance the propeller.

### CONTROL THROWS

- 1) We highly recommend setting up a plane using the control throws listed.
- 2) The control throws should be measured at the widest point of each control surface.
- 3) Check to be sure the control surfaces move in the correct directions.

Low rate:

- Aileron: 12 mm up 12 mm down
- Elevator: 14mm up 14 mm down
- Rudder: 25mm right 25mm down
- Flap: 25 mm down for take off

High rate:

- Aileron: 14 mm up 14 mm down
- Elevator: 16 mm up 16 mm down
- Rudder: 30 mm right 30 mm left
- Flap: 35 mm down for landing

## FOR YOUR RADIO INSTALLATION BASIC CONNECTION FOR AIRPLANE AND ADJUSTMENT OF SERVOS

Example of connection

- For more information, refer to radio system instruction manual.
- Follow instruction manual of Engine and Battery.

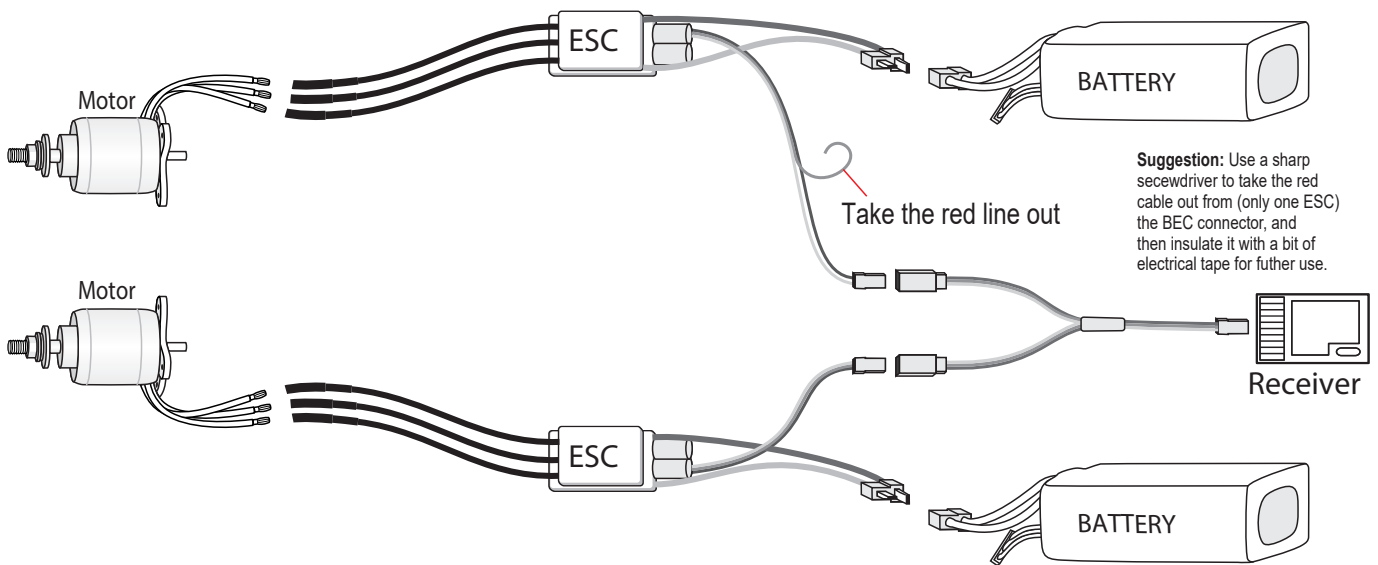
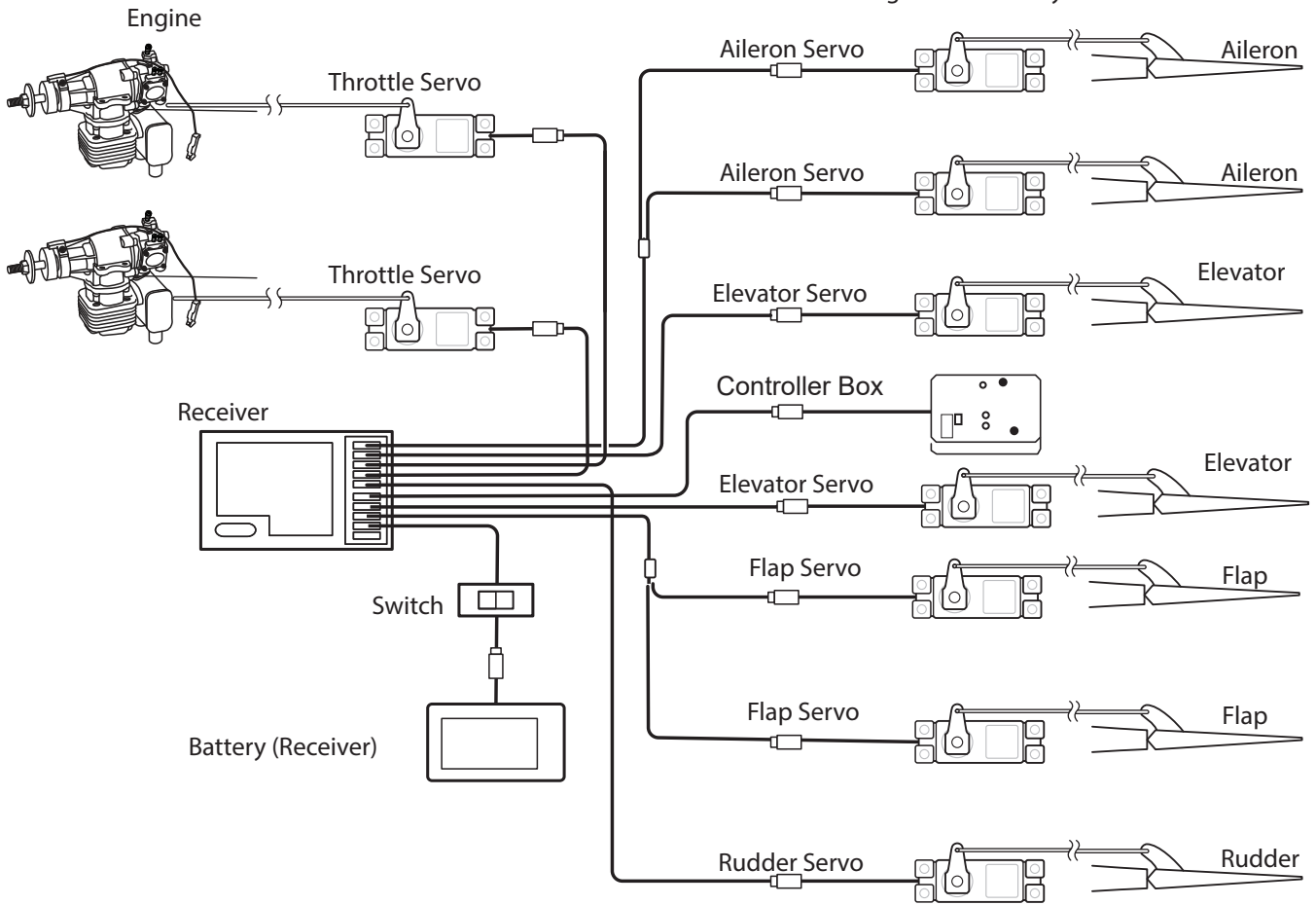

### MAIN GEAR DIMENSIONAL DETAIL

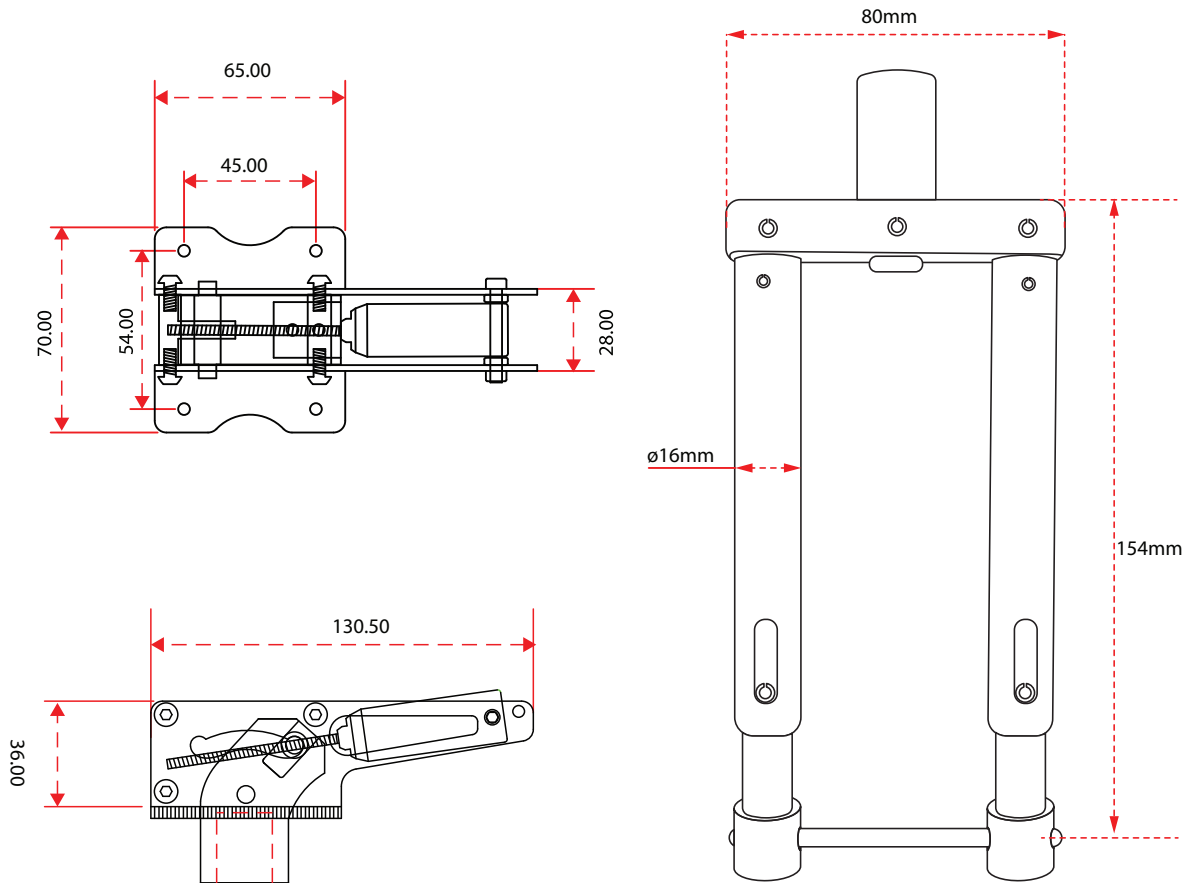

### TAIL GEAR DIMENSIONAL DETAIL

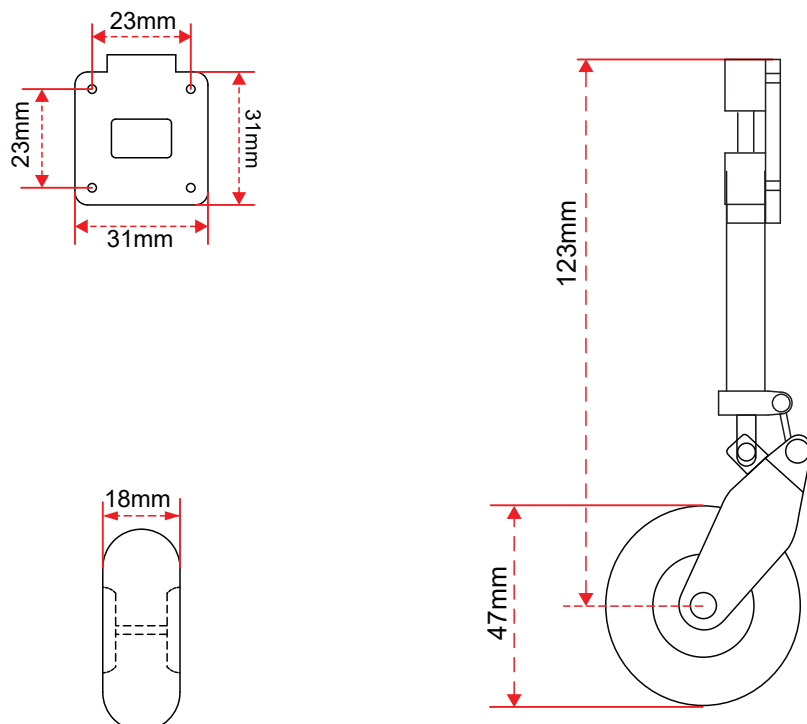

DECORATION

< Top view >

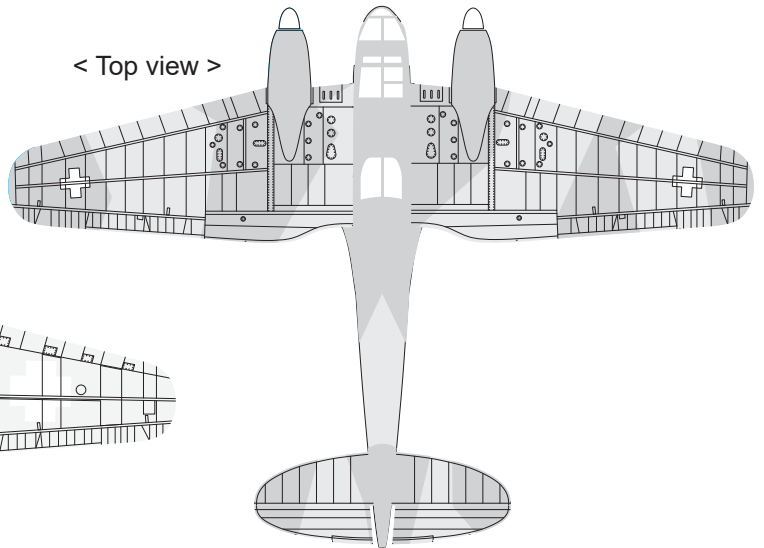

< Bottom view >

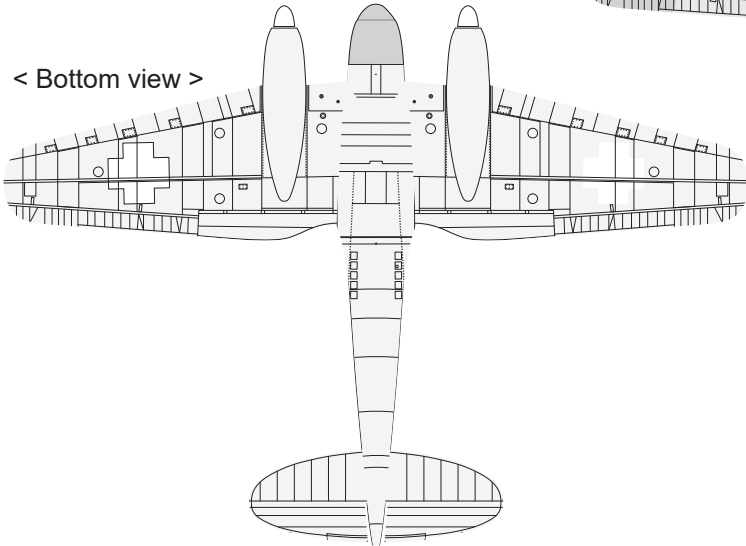

< Side view > Left

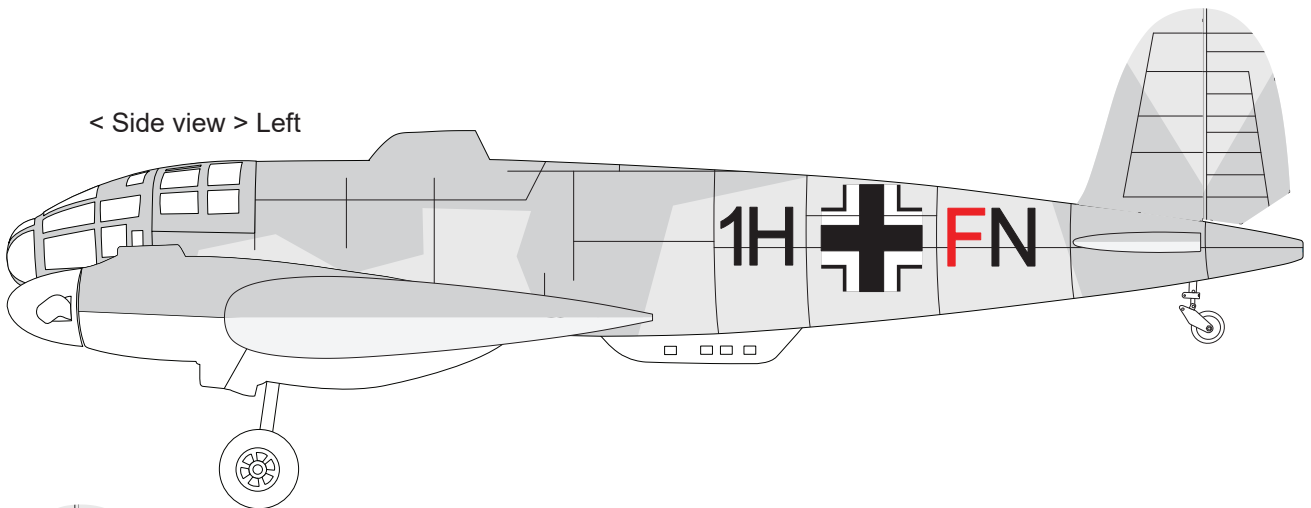

< Side view > Right

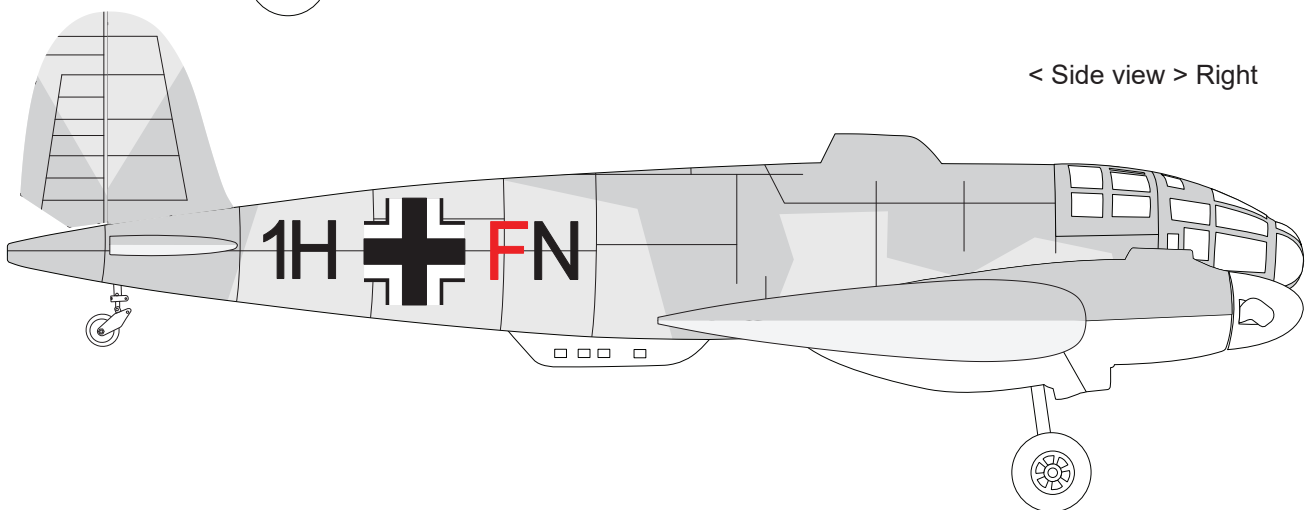

# EXPLODED VIEW

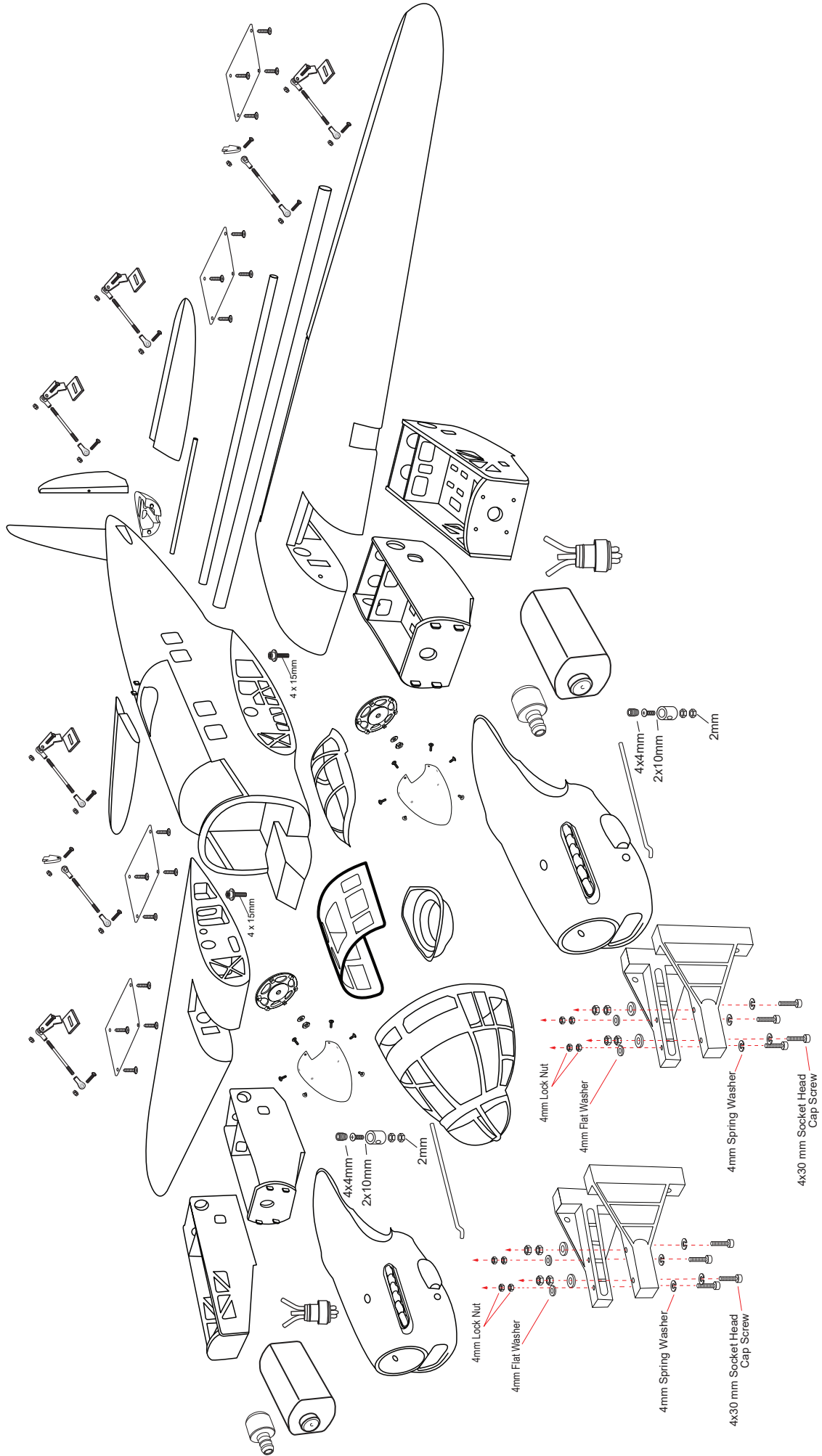

# I/C FLYING WARNING

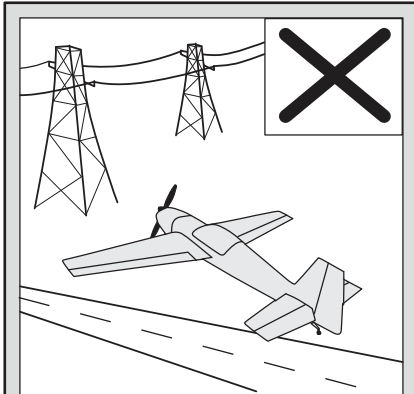

**NEVER** fly near power lines, aeriels or other dangerous areas including airports, motorways etc.

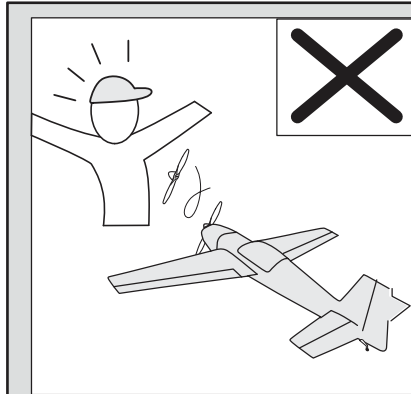

**ALWAYS** adjust the engine from behind the propeller, and do not allow any part your body to be in line with the propeller.

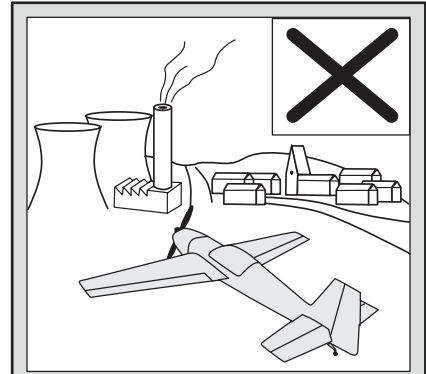

Always operate in open areas, away from factories, hospitals, schools, buildings and houses etc. **NEVER** fly your aircraft close to people or built up areas.

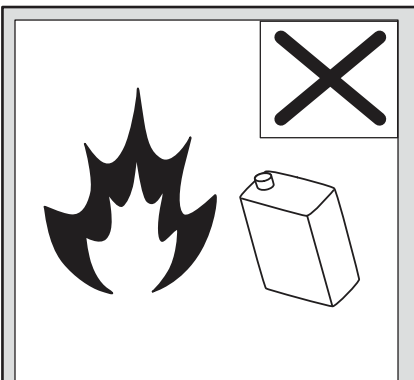

**DO NOT** dispose of empty fuel containers on a fire, this can lead to an explosion.

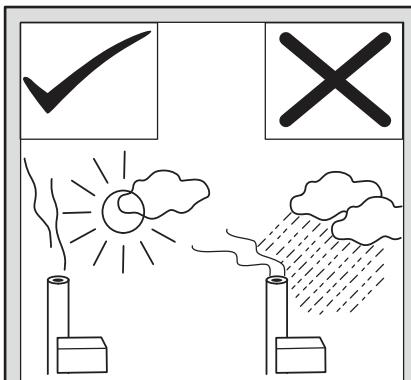

**NEVER** fly in wet conditions or on windy or stormy days.

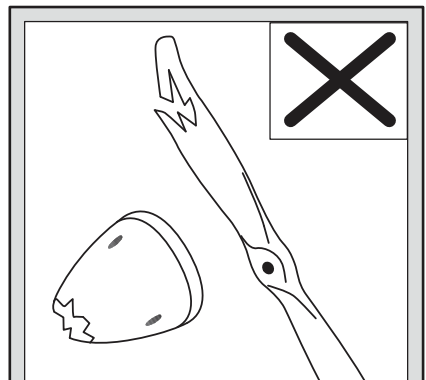

**NEVER** use damaged or deformed propellers or spinners.

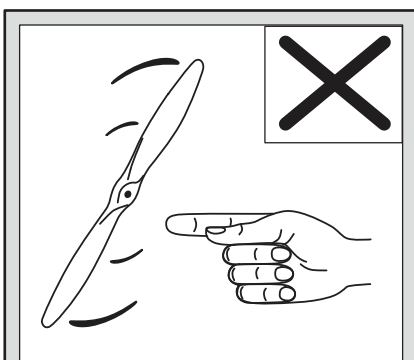

## THE PROPELLER IS DANGEROUS.

Keep fingers, clothing (ties, shirtsleeves, scarves) or any other loose objects that could be caught or drawn in, away from the propeller. Take care at **ALL** times.

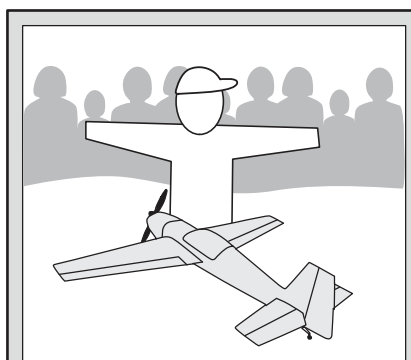

Keep all onlookers (especially small children and animals) well back from the area of operation. This is a flying aircraft, which will cause serious injury in case of impact with a person or animal.

# I/C FLYING GUIDE

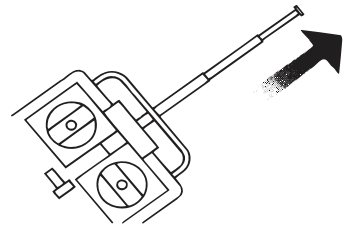

When ready to fly, first extend the transmitter aerial.

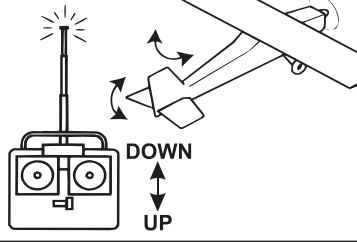

Operate the control sticks on the transmitter and check that the control surfaces move freely and in the CORRECT directions.

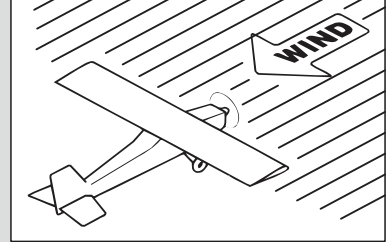

ALWAYS land the model INTO the wind, this ensures that the model lands at the slowest possible speed.

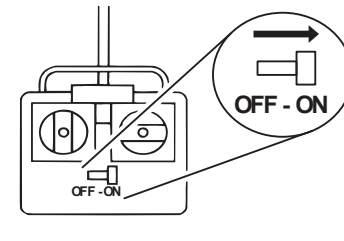

Switch on the transmitter.

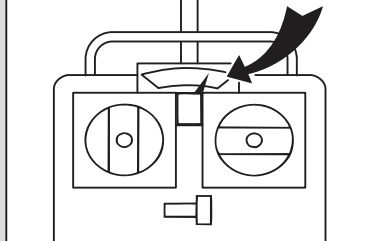

Check that the transmitter batteries have adequate power.

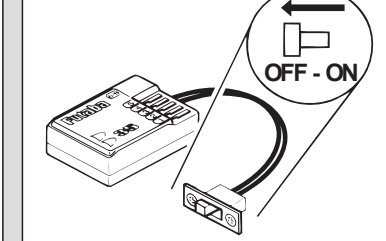

Switch off the receiver .

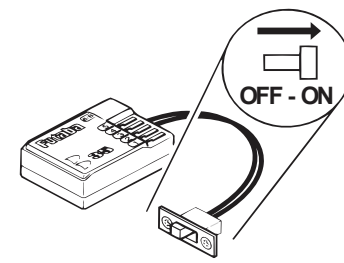

Switch on the receiver .

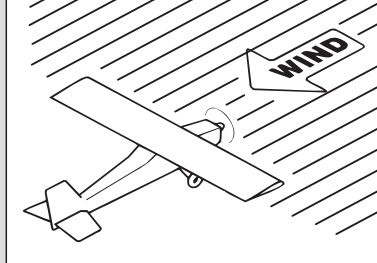

ALWAYS take off into the wind.

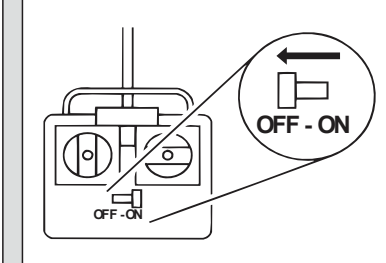

Switch off the transmitter .

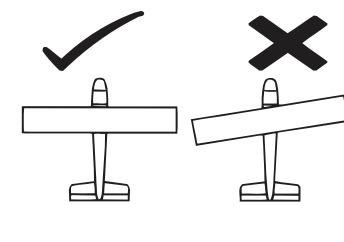

Check that the wings are correctly fitted to the fuselage.

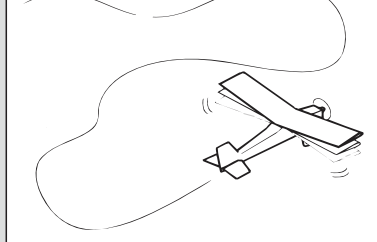

If the model does not respond correctly to the controls, land it as soon as possible and correct the fault.

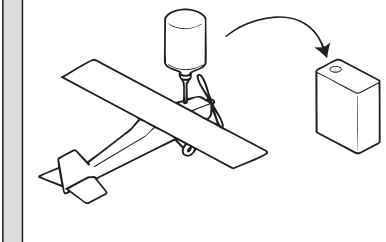

Empty the fuel tank after flying, fuel left in the tank can cause corrosion and lead to engine problems.